

NATIONAL-SPENCER INC.

Fluid
Management
Equipment

Trusted For Generations



Product Catalog

2017

Top Twelve Best Sellers



912-19

- 19.2V Battery Operated Grease Gun
- Pg. 48



321

- Gear Lube Hand Pump
- Pg. 25



375

- Chemical/DEF Lever Pump
- Pg. 80

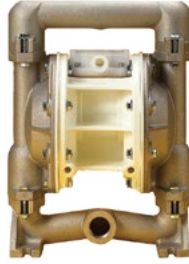

1040

- 1" Double Diaphragm Pump
- Pg. 12



1504

- Non-Preset Digital Meter
- Pg. 18



D-S

- Oil Lever Pump for 15-55 gallon drums
- Pg. 26



1712

- 3:1 Air Ratio Oil Pump
- Pg. 6



3574R

- 50:1 Air Ratio Greasing System for 5 gallon pails
- Pg. 38



1444R

- 49' Heavy-Duty Oil Reel
- Pg. 86



10211

- Chemical/DEF Rotary Pump for 15-55 gallon drums
- Pg. 79



227

- Low Profile Truck Drain
- Pg. 31



HD4A

- Premium Lever Grease Gun
- Pg. 53

Best Selling New Item from 2016



7019

- Battery Operated Chemical/DEF Pump
- Pg. 70



Look for the "Best Seller" stamp to identify Best Selling items.

Table of Contents

Top 12 Best Sellers Inside Cover

Table of Contents 3

Oil Equipment 4-35

Section Contents 4
Oil Equipment Packages 5
Air Operated Oil Pumps 6-15
Oil Dispensing Stations 9
Metered Control Handles 16-21
Non-Metered Control Handles 22
Tote Mounted Equipment 23
Electric Oil Pump 24
Hand Pumps 25-30
Waste Oil Drains 31-35

Grease Equipment 36-59

Section Contents 36
General Information 37
Air Operated Grease Systems 38-42
Grease Handles 43
Follower Plates 44
Hand Grease Pumps 45
Bearing Packers 46
Grease Gun Filler Pumps 47
Grease Guns 48-53
Grease Gun Accessories 54-55
Grease Couplers 56-57
Grease Fittings 58-59

Fuel Equipment 60-68

Section Contents 60
Electric Fuel Pumps 61-62
Hand Fuel Pumps 63-66
Fuel Accessories 67-68

DEF Equipment 69-75

Section Contents 69
Battery Operated Pump 70
DEF Pumping Systems 71-73
Hand Pumps 74
Couplers & Accessories 75

Chemical Equipment 76-81

Section Contents 76
Air Operated Pumps 77
Hand Pumps 78-81

Specialty Pumps 82

Value Pumps 83

Accessories 84-101

Section Contents 84
Hose Assemblies 85
Hose Reels 86-87
Drum Equipment 88-92
Air Sentry Breathers 93
Funnels 94-95
Measures & Containers 96
Electrical Reels 97
Air Controls 98
Tools 99
Industrial Cleaning Products 100-101

Chemical Resistance Chart . . . 102-103

Index by Part Number 104-107

Product UPC Numbers 108-113

Maximum Response Team 114

New Products Inside Cover

Section Contents



Oil Equipment 4-35

Oil Equipment Packages 5

Air Operated Oil Pumps 6-15

Piston Pump: A-Series	6-8
Oil Dispensing Stations	9
Piston Pump: R-Series	10-11
Double Diaphragm Pumps.....	12-14
Vacuum Pump: Industrial Shop-Vac	15

Metered Control Handles 16-21

Preset Meters: Digital	16
Preset Meters: Mechanical	17
Digital Meters: Non-Preset	18-19
Mechanical Meters: Non-Preset	20-21

Non-Metered Control Handles & Accessories.....22

Tote Mounted Equipment23

Electric Oil Pump & Portable Oil Dispensing Systems ..24

Hand Pumps..... 25-30

Suction Gun & Bucket Pumps	25
Economical Drum Pumps.....	26
Quart Stroke	27
Lever Style.....	28
Premium Lever Style.....	29
Lift Style.....	30

Waste Oil Drains.....31-35

Low Profile Truck Drains	31
Lift/Gravity Drains.....	32-33
Oil Evacuation Units	34
Pantograph Suction/Drainer.....	35

Oil Related Accessories

Hose Assemblies & Hose Reels	85-87
Drum Equipment	88-92
Funnels, Drain Pans, Measures & Containers	94-96
Air Controls.....	98



OIL EQUIPMENT PACKAGES



Basic Packages: Pumps on Pg. 6, 11; Reels on Pg. 86; Meters on Pg. 17, 18, 20.

Package #	Pump	Reel / Hose	Meter / Handle
6104	3:1 Stub (1712)	25' Hose (2225)	Digital Quart (1504)
6105	3:1 Stub (1712)	49' Reel (1444R)	Digital Quart (1504)
6112	3:1 Stub (1712)	49' Reel (1444R)	Mechanical (1515)
6116	3:1 Stub (1712)	32' Reel (1475R)	Mechanical (1515)
6120	3:1 Stub (1712)	49' Reel (1444R)	Mechanical Preset (1520)
6124	3:1 Stub (1712)	32' Reel (1475R)	Digital Quart (1504)
6204	3:1 55 Gallon (1702R)	25' Hose (2225)	Digital Quart (1504)
6520	5:1 Stub (1730A)	49' Reel (1444R)	Mechanical Preset (1520)

4-Wheel Cart Packages: Include a 4-wheel cart (148) Pg. 88.

Package #	Pump	Reel / Hose	Meter / Handle
6401	3:1 (1702R) fits 55 Gallon Drum	32' Reel (1475R)	Digital Quart (1504)
6403	3:1 (1714) fits 55 Gallon Drum	32' Reel (1475R)	Mechanical (1515)
6404	3:1 (1702R) fits 55 Gallon Drum	32' Reel (1475R)	Mechanical (1515)
6405	5:1 (1745) fits 55 Gallon Drum	32' Reel (1475R)	Digital Quart (1504)



6403

Tote Mounting Packages: Include a Tote Bracket (6601), and Suction Tube (15216).

Package #	Pump	Reel / Hose	Meter / Handle
6611	3:1 Stub (1712)	32' Reel (1475R)	Mechanical (1525G)
6612	3:1 Stub (1712)	32' Reel (1475R)	Mechanical (1515)
6613	3:1 Stub (1712)	25' Hose (2225)	Digital Quart (1504)
6614	3:1 Stub (1712)	32' Reel (1475R)	Digital Quart (1504)



6611



1559A-ASSY

ALL Equipment packages include (1559A-ASSY), which consists of a night time drain, regulator, gauge, ball valve, and the male and female quick disconnect couplers. Packages also include other connecting components.

AIR OPERATED OIL PUMPS



Piston Pump: A-Series



(1712)

Pump Not Suitable for Water Based Fluids

Air Ratio

The *Air Ratio* describes the amount of work an Air Operated oil pump is able to do. To figure the output PSI, you multiply the first number of the ratio by the air pressure being fed into the pump. For example, if the air pressure going into a 3:1 pump is 100 PSI, then the output pressure will be 300psi.

Air Ratio	Max. Delivery Distance
1:1	25 ft
3:1	50 ft
5:1	150 ft

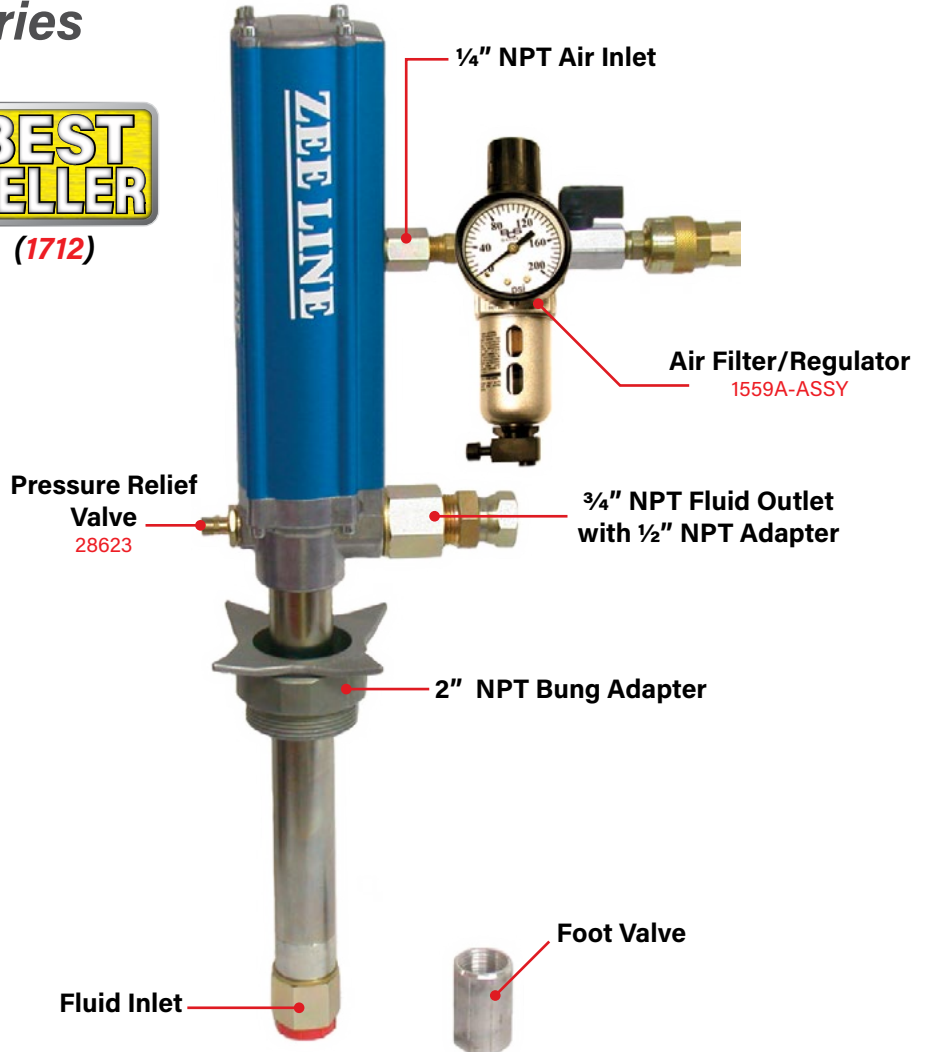

Model (Air Ratio)	1737 (1:1)	1712 (3:1)	1730A (5:1)
Max. Delivery	10.5 GPM	5.8 GPM	10 GPM
Max. Fluid Viscosity	80/90 SAE	80/90 SAE	240 SAE
Max. Fluid PSI	145 PSI	435 PSI	725 PSI
Max. Air PSI	145 PSI	145 PSI	145 PSI
Air Consumption	12.36 CFM @ 100 PSI	17.02 CFM @ 100 PSI	29.06 CFM @ 100 PSI
Air Inlet Size	1/4" NPT	1/4" NPT	1/4" NPT
Fluid Inlet Size	1" NPT	3/4" NPT	1" NPT
Fluid Outlet Size	3/4" NPT with 1/2" NPT Adapter	3/4" NPT with 1/2" NPT Adapter	3/4" NPT with 1/2" NPT Adapter

Height Dimensions	1737 (1:1)	1712 (3:1)	1730A (5:1)

**Use a 5:1 ratio pump to lift fluid more than 20 feet.



All Zeeline Air Operated Pumps feature our *Diamond Selection* 5-year limited warranty.

Quality products backed by premium customer service.

Air Operated Oil Pump Packages						
Included Parts	1737	1712	1713	1714	1716	1730A
PVC Extension	-	-	3/4" X 24" (15210) Fits 16-gal drum	3/4" X 28" (15212) Fits 55-gal drum	3/4" X 36" (15214) Fits 275-gal tote	-
Bung Adapter	28595	28585	28585	28585	28585	28595
Foot Valve	200-171	770-433	770-433	770-433	770-433	200-171
Misc.	-	-	16gal Drum Cover 680-823	-	-	-

Above Packages also include:

- 4' Air Hose (2004)
- 4' Oil Hose (2204)
- Air Regulator (1559A-ASSY)
- Pressure Relief Valve (28623)

Available Accessories:

1/2" Oil Hoses

- 1/2" I.D. Fiber Braid
- Max. Pressure 1,125-lbs.
- Min. Burst Pressure 4,500-lbs.
- Pressure fittings 1/2" NPT (M) both ends.



Part #	Length
2204	4'
2205	5'
2210	10'
2215	15'
2220	20'
2225	25'
2250	50'

Oil Reels

- All steel construction
- Dual arm support
- Durable powder coated finish
- Max. Pressure 2500 PSI
- Inlet Thread 1/2" NPT (F)
- Outlet Thread 1/2" NPT (M)
- See Pg. 86 for more details
- Compatible with ALL Zeeline oil pumps

Part #	Length
1475R	32'
1444R	49'



PVC Pickup Tubes

Part #	Container	Dimensions	Compatible Pump
15219	16 gallon	1" x 24"	1737, 1730A
15221	55 gallon	1" x 28"	1737, 1730A
15222	275 gallon	1" x 36"	1737, 1730A

91

- Wall Mount Bracket with 2" bung hole

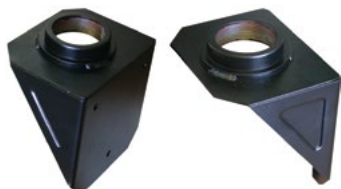

92

- Suction Kit



AIR OPERATED OIL PUMPS



A-Series: Power Pump Valves

ORDERS MUST SPECIFY "LOCKING" OR "NON-LOCKING" SPIGOTS

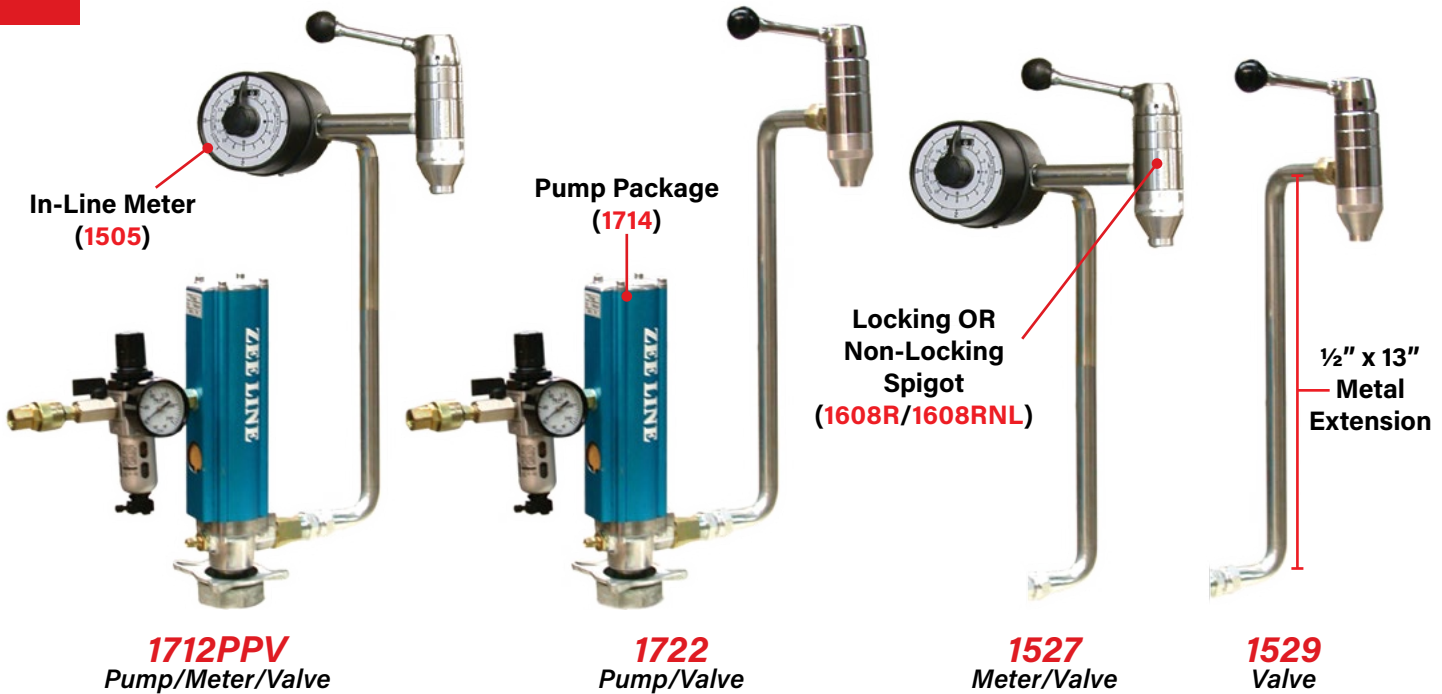

Model	1712PPV	1722
Oil Pump	1714 (3:1)	1714 (3:1)
Power Pump Valve	Power Pump Valve (1527)	Power Pump Valve (1529)
Meter	In-Line Meter (1505) Registers to 16 Quarts	No Meter
Max. Delivery	5.8 GPM	5.8 GPM
Max. Fluid Viscosity	80/90 SAE	80/90 SAE
Max. Fluid PSI	435 PSI	435 PSI
Air Consumption	17.02 CFM @ 100 PSI	17.02 CFM @ 100 PSI
Air Inlet	1/4" NPT	1/4" NPT
Fluid Inlet	3/4" NPT	3/4" NPT
Fluid Outlet	3/4" NPT (w/ 1/2" NPT Adapter)	3/4" NPT (w/ 1/2" NPT Adapter)
Stub Pump Length	21 1/2"	21 1/2"

Features for (1505) meter:

- Registers to 16 quarts per delivery
- Totalizes to 9,999 quarts
- Mechanical function
- Easy to read dial

(1712PPV) & (1722) include:

- 4' Air Hose (2004)
- 4' Oil Hose (2204)
- Air Filter/Regulator (1559A-ASSY)
- Bung Adapter (28585)
- Foot Valve w/Screen (770-433)
- 28" Pick-Up Tube (15212)
- Pressure Relief Valve (28623)



Spigot Only

- Locking: 1608R
- Non-Locking: 1608RNL



OIL DISPENSING STATIONS



Oil Bars

Dispensing Stations

Power Pump Valves and Oil Bars are ideal for setting up Oil Dispensing Stations. Measures can be brought to the stations and filled to the desired amount, then taken to the vehicle and dispensed accordingly.

ORDERS MUST SPECIFY "LOCKING" OR "NON-LOCKING" SPIGOTS

Non-Metered



Metered



Features for All Models:

- Anti-splash filter on oil tap
- Self Closing or Lock Open spigots
- Easy to clean removable drip tray

Size:

- Height: 26 ½"
- Width: 22"
- Depth: 17"

Available Configurations: **Locking**

Model	# of Taps	# of Meters
1610R	1	-
1620R	2	-
1630R	3	-
1615R	1	1
1625R	2	2
1635R	3	3

Available Configurations: **Non-Locking**

Model	# of Taps	# of Meters
1610RNL	1	-
1620RNL	2	-
1630RNL	3	-
1615RNL	1	1
1625RNL	2	2
1635RNL	3	3

Optional Accessories:

- Spigot Kit for additional oil taps (**16110R**). Includes (**1608R** Locking)
- Spigot and Meter Kit for additional oil taps w/meter (**16111R**). Includes (**1608R** Locking)
- 30" Hose (**HS1600**)

HS1600



1504AR

- ALL Metered Oil bars include (**1504AR**)
- Dispenses in: Pints, Quarts, Liters, and Gallons
- Totalizes in: Gallons or Liters



AIR OPERATED OIL PUMPS

Piston Pump: R- Series



Air Ratio	Max. Delivery Distance
1:1	25 ft
3:1	50 ft
5:1	150 ft

All three models include:

- 4' Air Hose (2004)
- 4' Oil Hose (2204)
- Air Regulator (1559A-ASSY)
- Bung Adapter (38042)
- Foot Valve (KR3308)

Optional PVC Pickup Tubes:

Part #	Container Size	Extension
15219	16 - gallon drum	PVC 1" X 24"
15221	55 - gallon drum	PVC 1" X 28"
15222	275 - gallon drum	PVC 1" X 36"

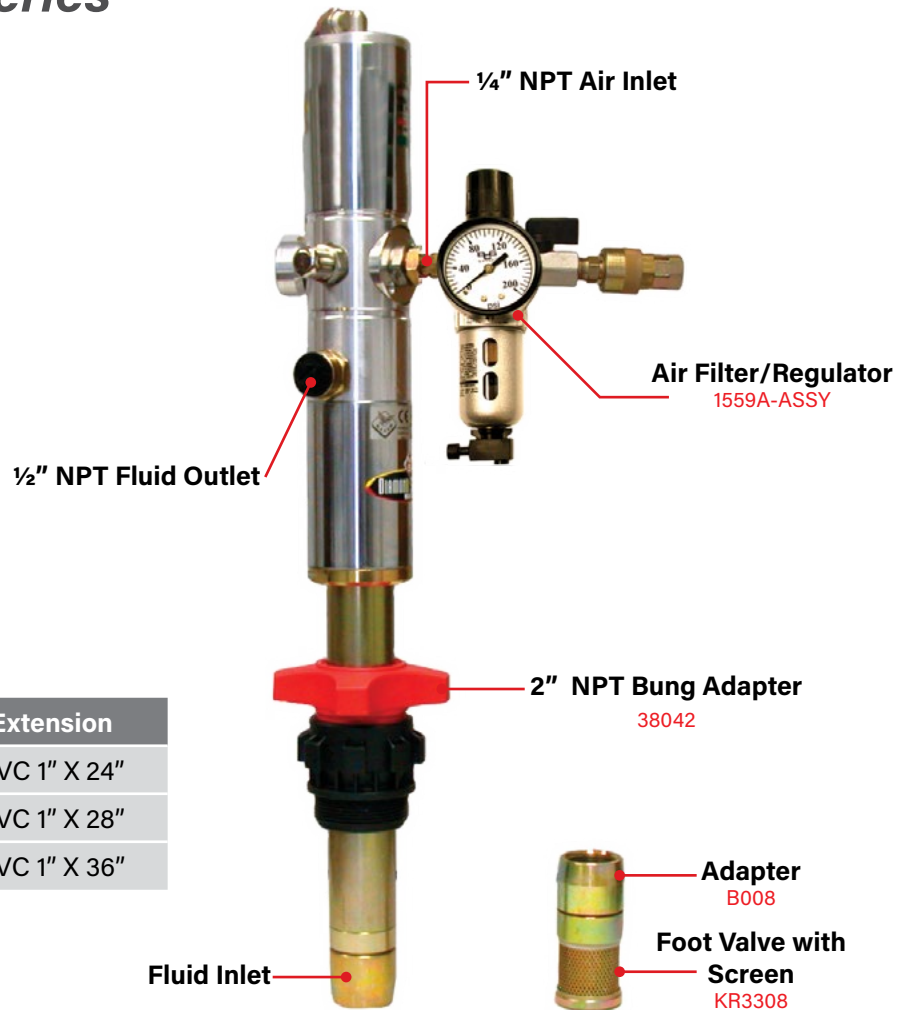

Model (Air Ratio)	1735R (1:1)	1700R (3:1)	1730R (5:1)
Max. Delivery	6 GPM	3.7 GPM	4.7 GPM
Max. Fluid Viscosity	80/90 SAE	80/90 SAE	240 SAE
Max. Fluid PSI	110 PSI	330 PSI	550 PSI
Max. Air PSI	110 PSI	110 PSI	110 PSI
Air Consumption	13 CFM @ 100 PSI	11.65 CFM @ 100 PSI	12.36 CFM @ 100 PSI
Air Inlet Size	1/4" NPT	1/4" NPT	1/4" NPT
Fluid Inlet Size	1" NPT	1" NPT	1" NPT
Fluid Outlet Size	1/2" NPT	1/2" NPT	1/2" NPT
Height Dimensions			

AIR OPERATED OIL PUMPS

Piston Pump: R- Series

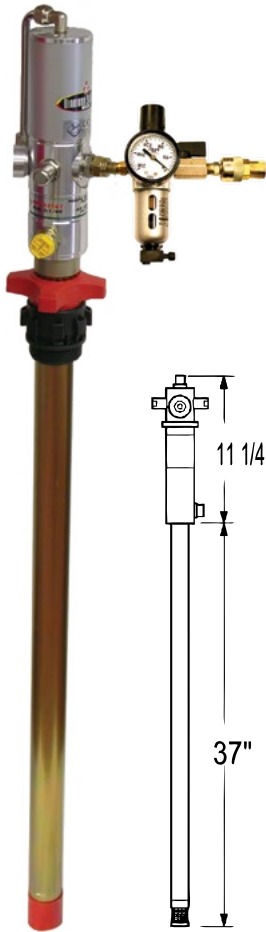

1702R

Fixed Length Pumps

These pumps are designed to fit a 55 gallon drum and made to work without a PVC extension. The pickup tubes are built into the air motor and can not be shortened or extended.



All Air Operated Pumps feature a 5 Year Limited Warranty.

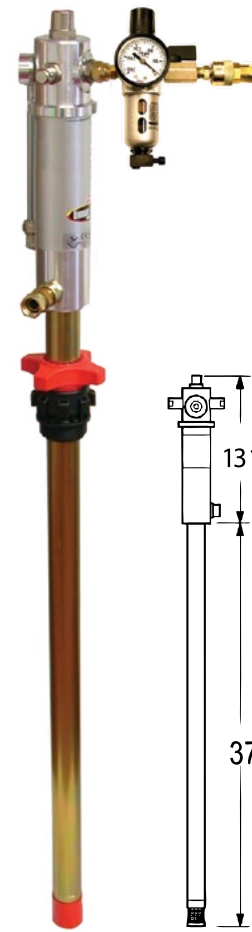

1745

Model (Air Ratio)	1702R (3:1)	1745 (5:1)
Max. Delivery	3.7 GPM	4.7 GPM
Max. Fluid Viscosity	80/90 SAE	240 SAE
Max. Fluid PSI	330 PSI	550 PSI
Max. Air PSI	110 PSI	110 PSI
Air Consumption	11.65 CFM @ 100 PSI	12.36 CFM @ 100 PSI
Air Inlet Size	1/4" NPT	1/4" NPT
Fluid Inlet Size	1" NPT	1" NPT
Fluid Outlet Size	1/2" NPT	1/2" NPT
Pump Length	48 1/4"	50 1/2"

(1702R) & (1745) Include:

- 4' Air Hose (2004)
- 4' Oil Hose (2204)
- Air Regulator (1559A-ASSY)
- Bung Adapter (38042)
- Foot Valve (KR3308)

Optional Accessory (28625): Pressure Relief Valve

- Highly recommended for ALL R-Series pumps
- Prevents damaging back pressure on pumps, meters, and reels



AIR OPERATED OIL PUMPS



Double Diaphragm Pumps

Non-stalling, Lube-free

Pumps Not Suitable
for Flammable Liquids



1035



1038



(1040)

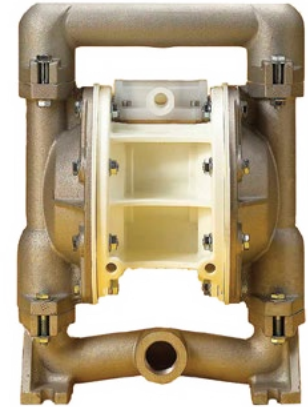

1040

Model	1035	1037**	1038	1040	1040UL	1040SS
Inlet/Outlet	½" NPT	½" NPT	¾" NPT	1" NPT	1" NPT	1" NPT
Max. Flow	14 GPM	14 GPM	14 GPM	37 GPM	37 GPM	37 GPM
Body Construction	Polypropylene	Polypropylene	Alum / Polypro	Alum / Polypro	Aluminum	Stainless Steel
Diaphragms	Buna N	Buna N	Buna N	Buna N	Buna N	PTFE
Balls	Acetal	Acetal	Acetal	Acetal	PTFE	PTFE
Seats	Polypropylene	Polypropylene	Aluminum	Aluminum	Aluminum	PTFE
UL Listed	No	No	No	No	Yes	No
Air Consumption	16CFM @ 100 PSI	16CFM @ 100 PSI	16CFM @ 100 PSI	40CFM @ 80 PSI	30CFM @ 50 PSI MAX PRESSURE 50 PSI	40CFM @ 80 PSI
Bolt Pattern	4.375" X 6.750"	4.375" X 6.750"	3.250" X 4.370"	4.250" X 8.250"	4.250" X 8.250"	4.250" X 8.250"
Height	10.600"	10.600"	10.250"	14.125"	15.125"	14.125"

**Model #1037 includes two ½" x 4' oil hose (2204), and an Air Line Filter assembly (1559A2-ASSY).

All Air Operated Pumps feature a 5 Year
Limited Warranty.



1040UL

- Includes a grounding cable and is recommended for Gasoline and Diesel

1040SS

- Recommended for Diesel, Bio Diesel, and other mild chemicals

When pumping flammable
liquids, use proper grounding!

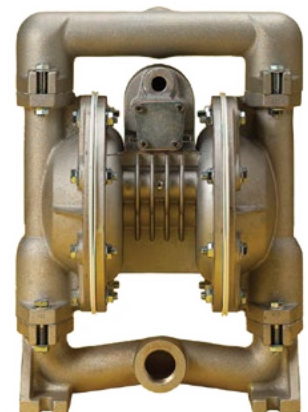

AIR OPERATED OIL PUMPS

Available Kits and Accessories



103501



104001



1035K / 1040K

Pump Kits & their Contents

Description	Qty	103501	104001	1035K	1035K2	1040K
Compatible Pump	-	1035	1040	1035	1035	1040
Included Pump	1	None	None	1035	1035	1040
Male Cam Lock	1	3/4" (61961)	1" (61962)	3/4" (61961)	3/4" (61961)	1" (61962)
Female Cam Lock	1	3/4" (61921)	1" (61922)	3/4" (61921)	3/4" (61921)	1" (61922)
Brass Ball Valve	3	3/4"	1"	3/4"	3/4"	1"
Hydraulic Adapter Swivel	2	1/2" x 3/4"	1" x 1"	1/2" x 3/4"	1/2" x 3/4"	1" x 1"
Galvanized Steel Street L	1	3/4"	1"	3/4"	3/4"	1"
Suction Hose	1	3/4" x 8'	1" x 8'	3/4" x 8'	3/4" x 8'	1" x 8'
Discharge Hose	1	3/4" x 8'	1" x 8'	3/4" x 8'	3/4" x 8'	1" x 8'
Nipple	2	3/4" x 2"	1" x 2"	3/4" x 2"	3/4" x 2"	1" x 2"
Strainer	1	3/4"	1"	3/4"	3/4"	1"
Wall Mount Bracket (96)	1	Yes	Yes	Yes	Yes	Yes
Airline Filter (1559A2-ASSY)	1	Yes	Yes	Yes	Yes	Yes
Reducer Bushing (1035RB)	1	No	Yes	No	Yes	Yes

98

- Diaphragm Pump Adapter
- Mounts directly to a 2" NPT bung on drums and tanks
- Includes locking nut (104006-975)
- Compatible with 1035/1038 only



Adapter Kits: Kits include (1035) Diaphragm Pump

Kit #	Pump Hose	Control Handle
9810	10' (2210)	1572G
9825	25' (2225)	1572G

96

- Wall Mount Pump Bracket
- 6" Wide x 11" Deep



1559A2-ASSY

- Airline filter with nighttime drain, regulator, gauge, ball valve, and quick disconnects



AIR OPERATED OIL PUMPS



Double Diaphragm Pumps High-Flow Industrial

Pumps Not Suitable
for Flammable Liquids



1041



1043



1044

Model	1041	1043	1044
Inlet/Outlet	1 ½" NPT	2" NPT	3" NPT
Max. Flow	72 GPM	155 GPM	260 GPM
Air Inlet Port	½" NPT	½" NPT	½" NPT
Max Particle Size	⅜"	¼"	⅜"
Suction Lift - Dry	15'	20'	20'
Suction Lift - Wet	25'	25'	25'
Body Construction	Aluminum	Aluminum	Aluminum
Diaphragms	Buna N	Buna N	Buna N
Balls	Buna N	Buna N	Buna N
Seats	Buna N	Buna N	Buna N
UL Listed	No	No	No
Air Consumption	50CFM @ 80 PSI	100CFM @ 100PSI	100CFM @ 100 PSI
Bolt Pattern	6.00" X 8.750"	10.00" X 9.00"	10.00" X 14.250"
Height	18.00"	26.500"	32.750"



All Air Operated Pumps feature a 5 Year
Limited Warranty.

AIR OPERATED OIL PUMPS

Vacuum Pump: Industrial Shop-Vac



**Pumps Not Suitable
for Flammable Liquids**

Industrial Shop-Vac

The 1785 is not an oil pump. It is used to fill a container rather than emptying one. The depiction below shows a man removing the residual sludge from a bulk storage tank and filling a 55-gallon drum with it. The 1785 must be attached to a sealed container to generate vacuum. Be careful when increasing the air pressure. If too much pressure is used, the vacuum generated is powerful enough to crumple a steel drum.



1785

- Converts 55 or 120-gallon container into a recovery tank.
- No moving parts.
- Automatic shutoff when container is full.

Applications:

- Waste oil transfer / Cutting fluids
- Paint booth water boxes
- Marinas and many other industrial uses

Pump must be attached to a SEALED container to generate suction.

108-5110

- 5-gallon recovery container
- Heavy-duty construction
- 2" NPT Bung Opening



Preset Meters: Digital

Preset Meter

A preset meter allows you to program the amount of fluid you want to dispense, setting it to where the meter will shut off once it has dispensed that amount.



1517



1522

Model	1517	1522
Dispenses	Pints, Quarts, Liters, and Gallons	Pints, Quarts, Liters, and Gallons
Totalizes	Pints, Quarts, Liters, and Gallons	Pints, Quarts, Liters, and Gallons
Inlet/Outlet	1/2" NPT Threads	1/2" NPT Threads
Nozzle	Flexible w/Automatic Non-Drip Tip	Rigid w/Automatic Non-Drip Tip
Max. PSI	725 PSI	1000 PSI
Max. Flow	4 GPM	8 GPM
Accuracy	± 1%	To Second Decimal
Batteries	2 AAA	4 AA
Inlet Swivel	1/2" NPT (N/A)	1/2" NPT (64082-001)
Safety Lock	Yes	Trigger Guard

METERED CONTROL HANDLES



OIL

Preset Meters: Mechanical

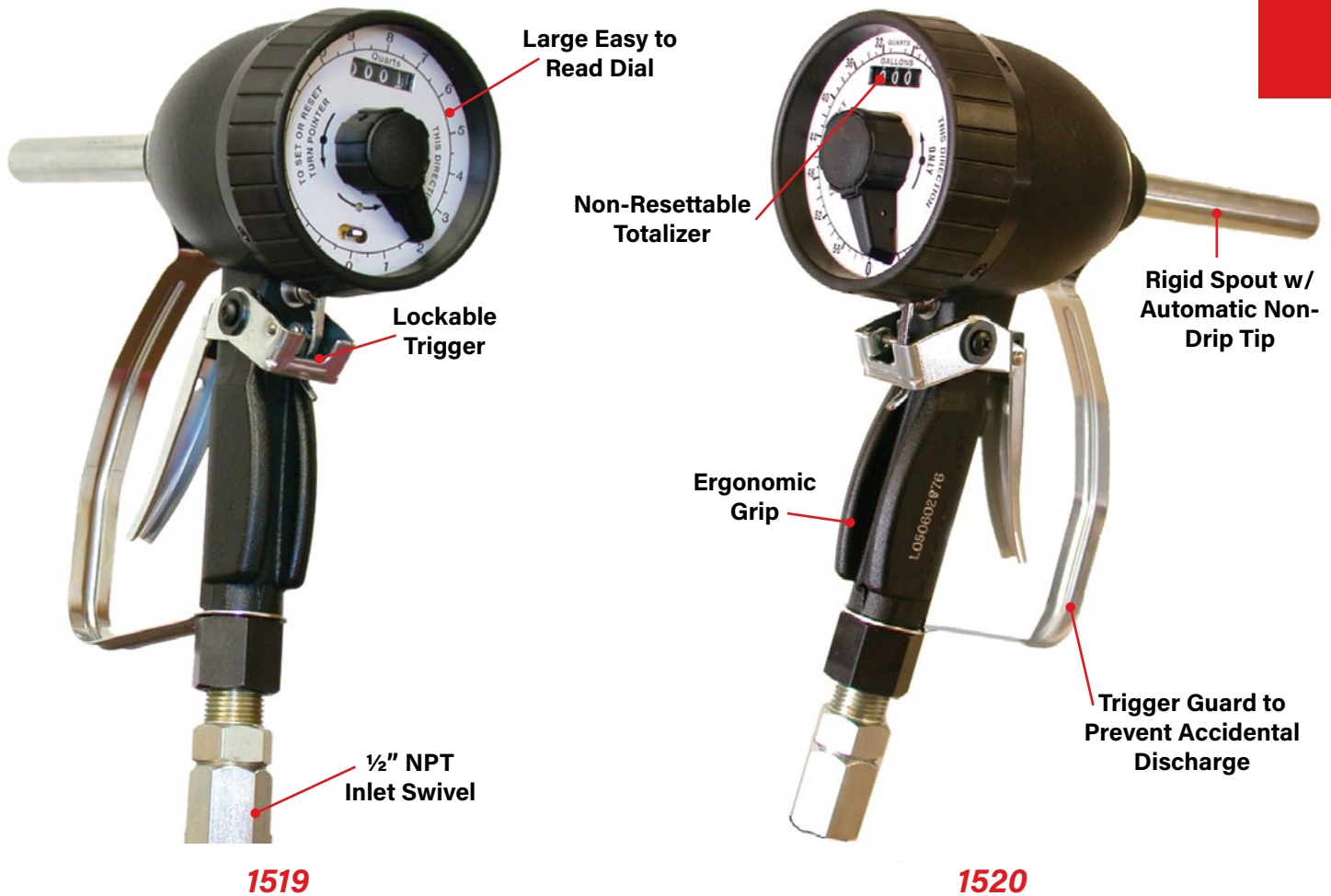

Features above are for all models listed below.

Model	1519	1519L	1520	1520L	1520GG
Dispenses	Quarts	Liters	Quarts	Liters	Gallons
Totalizes	Quarts	Liters	Gallons	Liters	Gallons
Preset	1-16 Quarts	1-16 Liters	1-60 Quarts	1-60 Liters	1-60 Gallons
Graduated	1/2 Quarts	1/2 Liters	Quarts	Liters	Gallons
Inlet/Outlet	1/2" NPT Threads	1/2" NPT Threads	1/2" NPT Threads	1/2" NPT Threads	1/2" NPT Threads
Nozzle	1/2" Pipe, Automatic Non-Drip (1340)	1/2" Pipe, Automatic Non-Drip (1340)	1/2" Pipe, Automatic Non-Drip (1340)	1/2" Pipe, Automatic Non-Drip (1340)	1/2" Pipe, Automatic Non-Drip (1340)
Max. PSI	1000 PSI	1000 PSI	1000 PSI	1000 PSI	1000 PSI
Max. Temp.	150°	150°	150°	150°	150°
Max. Flow	4.0 GPM	4.0 GPM	4.0 GPM	4.0 GPM	4.0 GPM
Min. Flow	0.4 GPM	0.4 GPM	0.4 GPM	0.4 GPM	0.4 GPM
Accuracy	±0.65%	±0.65%	±0.65%	±0.65%	±0.65%
Inlet Swivel	1/2" NPT (1101)	1/2" NPT (1101)	1/2" NPT (1101)	1/2" NPT (1101)	1/2" NPT (1101)

METERED CONTROL HANDLES



Digital Meters: Non-Preset

Non-Preset Meter

A Non-Preset Meter will display the amount of fluid being dispensed, but will not shut off automatically. The dispensing total can be reset for every use.



1504

**BEST
SELLER**

(1504)



1507



1509

Model	1504	1507	1509
Dispenses	Pints, Quarts, Liters, and Gallons	Pints, Quarts, Liters, and Gallons	Pints, Quarts, Liters, and Gallons
Totalizes	Liters and Gallons	Liters and Gallons	Liters and Gallons
Inlet/Outlet	½" NPT Threads	½" NPT Threads	½" NPT Threads
Nozzle	½" Flex Hose, Automatic Non-Drip (1315A)	½" Flex Hose, Manual Non-Drip (1315)	½" Pipe, Automatic Non-Drip (1340)
Max. PSI	1500 PSI	1500 PSI	1500 PSI
Temp. Range	-4° F to 140° F	-4° F to 140° F	-4° F to 140° F
Max. Flow	4.0 GPM	4.0 GPM	4.0 GPM
Min. Flow	0.4 GPM	0.4 GPM	0.4 GPM
Accuracy	±0.5%	±0.5%	±0.5%
Inlet Swivel	½" NPT (1572GSW)	½" NPT (1572GSW)	½" NPT (1101)

Features for all models:

- Resettable dispenser
- Non-resettable totalizer
- Cast aluminum housing
- Scratch resistant oven baked epoxy finish
- Easy to read 6 digit LCD with .01 increment
- Long life field replaceable top load battery (CR123A)

1504AR

- Meter Only



METERED CONTROL HANDLES



OIL

Digital Meters: Non-Preset

High-Flow Meter

1590AR

- Meter Only

1590

- 20 GPM
- Oval gear driven design
- Large LCD display with two decimal point precision
- Field replaceable battery
- Optional rubber boot (629)

Model	1590
Max. Flow	20.0 GPM
Dispenses	Pints, Quarts, Liters, and Gallons
Totalizes	Gallons or Liters
Inlet/Outlet	3/4" NPT Threads
Nozzle	Flexible Hose w/Automatic Non-Drip Tip
Control Handle	Included (33150)
Handle Adapter	Included (33117)
Temp Range	4° F to 140° F
Accuracy	±0.5%
Inlet Swivel	3/4" NPT (38065)



Wireless Oil Management System

(OMS900524E):

- RF meter system for fluid inventory management and control
- Manages up to 30 meters using wireless 2.4ghz technology
- 4 hour installation time
- Range: 300-ft (unobstructed)
- Built in ticket printer
- External printer may be added
- Accommodates up to 30 meters per keypad
- Accommodates up to 8 fluids per keypad
- Operates in liters, gallons, pints, or quarts
- Maximum of 49 technicians may use the system
- Vehicle mileage may be entered
- Maximum of 1 supervisor password
- Self diagnostic system

System Includes:

- 1 - RF Meter (1522RF24)
- 1 - 110 Volt Keypad (OMS900724E)



OMS900724E



1522RF24

Available Accessory:

- Remote Antenna with 30' cable (64722-007)

Additional RF Meters (1522RF24):

- RF meter only works with this system
- The amount of fluid dispensed is preset and controlled by the keypad
- Top off feature may be implemented once the meter has stopped
- Meter uses 4 AA batteries
- Due to auto stand by, battery life is expected to last 6 months
- Outlet and spout (1341)

METERED CONTROL HANDLES



Mechanical Meters: Non-Preset/In-Line

Inlet/Outlet	Max. Flow	Min. Flow	Max. PSI	Max. Temp	Accuracy	Dial Size	Swivel
½" NPT	4.0 GPM	0.25 GPM	1000 PSI	150° F	±0.65%	3 ½"	½" NPT (1101)



1508



1515



1515A

Model	Dispenses	Totalizes	Dial Reads	Graduated	Nozzle
1508	Quarts	Quarts	1-16 Quarts	¼ Quarts	1340
1508L	Liters	Liters	1-10 Liters	⅒ Liters	1340
1508Q	Quarts	Quarts	1-16 Quarts	¼ Quarts	1335
1508G	Quarts	Gallons	1-16 Quarts	¼ Quarts	1340
1508GG	Gallons	Gallons	1-16 Gallons	¼ Gallons	1340
1515	Quarts	Quarts	1-16 Quarts	¼ Quarts	1315
1515L	Liters	Liters	1-10 Liters	⅒ Liters	1315
1515A	Quarts	Quarts	1-16 Quarts	¼ Quarts	1315A
1515G	Quarts	Gallons	1-16 Quarts	¼ Quarts	1315
1515GG	Gallons	Gallons	1-16 Gallons	¼ Gallons	1315

In-Line Meters:



1500

- For dispensing up to 8 pints
- Registers in ¼ pint increments



1502

- For dispensing and totalizing up to 8 pints
- Registers in ¼ pint increments



1505

- For dispensing and totalizing up to 16 quarts
- Registers in ¼ quart increments

METERED CONTROL HANDLES



OIL

Mechanical Meters: Non-Preset

Inlet/Outlet	Max. Flow	Min. Flow	Max. PSI	Max. Temp	Accuracy	Dial Size
1/2" NPT	4.0 GPM	0.25 GPM	1000 PSI	150° F	±0.65%	3 1/2"



1503



1525G

Meter Only



1525AR

Model	1503	1525G
Dispenses	Pints	Quarts
Totalizes	Pints	Quarts
Inlet/Outlet	1/2" NPT Threads	1/2" NPT Threads
Shroud	Optional (59628-001)	Standard
Nozzle	90° Pipe w/Manual Tip (1326)	Flex Hose w/Automatic Non-Drip Tip (1315A)
Handle	Integrated	Control Handle (1572G)
Swivel	1/2" NPT (1101)	1/2" NPT (1572GSW)



786

- Wall mounted oil meter holder and drip tray
- Used to catch drips from hanging oil meters

All Zeeline Oil Meters and Control Handles, mechanical and digital, feature a 2-year limited warranty.

Quality products backed by premium customer service.

NON-METERED CONTROL HANDLES

Control Handle Accessories



1572G

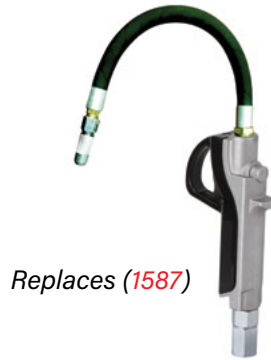

Replaces (1587)

1575G



1580G

Control Handle Body:

1572GAR

- Rugged Aluminum Body
- Slimline Ergonomic Design
- Inlet: 1/2" NPT
- Outlet: 1/2" NPT
- Includes 1/2" NPT Swivel (1572GSW)



Tips:

26



- Manual Non-Drip Nozzle
- 1/4" NPT

26A



- Automatic Non-Drip Nozzle
- 1/4" NPT



1572GSW

- 1/2" NPT Swivel

Nozzles and Spouts:



1315



1315A



1330



1335



1340

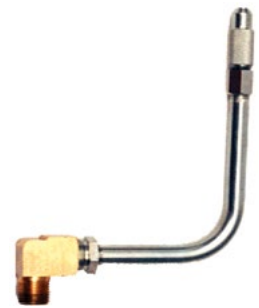

1326

Model	1315	1315A	1330	1335	1340	1326
Description	14" Flex-Hose w/Manual Non-Drip Nozzle (26)	14" Flex-Hose w/Automatic Non-Drip Nozzle (26A)	8" 30° Bent Pipe w/Manual Non-Drip Nozzle (26)	8" 15° bent pipe w/Manual Non-Drip Nozzle (26)	6" Straight Pipe with Automatic Non-Drip Nozzle (N/A)	16" 90° Bent Pipe w/Manual Non-Drip Nozzle (26)
Thread Size	1/2" x 1/4" NPT	1/2" x 1/4" NPT	1/2" x 1/4" NPT	1/2" x 1/4" NPT	1/2" NPT	1/2" x 1/4" NPT

TOTE MOUNTED EQUIPMENT

Tote Mounting Plate & Kits

Universal Tote Mounting Plate



6601

- Fits totes 39" to 41" wide; most 275 to 330-gallon totes
- Clamps to side rails of most shaped cages
- Steel construction with a scratch resistant powder coated finish
- 2" NPT threads for pump
- 2" filler neck with rubber cap
- Holes for mounting Zeeline reels
- Shipping Weight: 24lbs.
- Shipping Dimensions: 7" x 16" x 45"



Tote Not Included

Kit #	Pump	Reel / Hose	Meter / Handle
6611	3:1 Stub (1712)	32' Reel (1475R)	Mechanical (1525G)
6612	3:1 Stub (1712)	32' Reel (1475R)	Mechanical (1515)
6613	3:1 Stub (1712)	25' Hose (2225)	Digital Quart (1504)
6614	3:1 Stub (1712)	32' Reel (1475R)	Digital Quart (1504)

Kits include a Tote Bracket (6601), and Suction Tube (15216).

Features for Both (936G) & (938G):

- Pickup tube with built in screen
- Built in bypass valve with on and off switch
- Self-priming, positive displacement
- Air cooled motor with thermal protection

Model	936G	938G
Delivery Rate	4.4 GPM	8 GPM
Max. Oil Viscosity	90-wt. @ 50° F	90-wt. @ 50° F
Inlet	1" NPT	1" NPT
Outlet	¾" NPT	¾" NPT
Discharge Hose	¾" x 8'	¾" x 8'
Suction Tube	34" Steel	34" Steel
Motor	½ HP 115-Volt AC	½ HP 115-Volt AC
Max. Oil Temp.	150° F	150° F
Max. Outlet PSI	65 PSI	65 PSI
RPM	1720 RPM	3400 RPM



Control Valve

Portable Oil Dispensing Systems:**3024**

- 5-gallon wheel mounted tank for modern workplaces
- No pump needed
- Maximum air pressure 100 PSI
- Delivery hose and control handle
- Loading funnel features and anti-splash rim
- Level gauge

**5265**

- 17-gallon wheel-mounted tank
- 3:1 ratio pump (dispenses 3.7 GPM @ 90 PSI)
- Maximum air pressure 110 PSI
- Air consumption 12 CFM @ 100 PSI
- Digital meter (1504)
- Delivery hose (13' length, ½" diameter)
- 3" front and 6" rear wheels with ball bearings
- Loading funnel features and anti-splash rim
- Level gauge

Pumps Not Suitable for Flammable Liquids, Water Based Liquids, or Corrosive Liquids.

BEST SELLER

(321)



321

Gear Lube Pump

- For dispensing oils, ATF, and gear lube (max 140-wt.)
- Delivers approximately 1-gallon per 55 strokes
- Variable stroke handle
- Powder coated pail cover
- 4' vinyl hose with curved nozzle
- Buna N seal



101

Suction Gun

- 17-oz. Capacity
- 12" clear vinyl hose
- Powder-coated steel construction
- Buna N piston ring



353

Plastic Bucket Pump

- Attaches directly to pull-up spout on many 5-gallon pails, without a need to remove the plastic covers
- Includes 7 pump adapters for all types of pails
- Dispenses approximately 1-QT per 19 strokes
- Discharge hose is fitted with a non-drip tip
- Includes an extension for a 6 1/2-gallon pail
- 48" long hose with embedded spring
- Plastic pump head and steel tube
- Metal curved pump spout
- Down-stroke operation



HAND PUMPS

For 15-55 Gallon Drums



Pumps Not Suitable for Water Based Fluids



Features for all models:

- Variable stroke
- Durable powder coated finish

(381) & (382):

- Steel body with die cast aluminum head and base

(D-S) & (D-S1):

- All steel body

All four models include a telescoping PVC suction tube.

Steel replacement tube is available (**L30-99N**).



Model	381	382	D-S	D-S1
Delivery Rate	1-gal. per 9 strokes	1-gal. per 9 strokes	1-gal. per 9 strokes	1-gal. per 9 strokes
Variable Stroke	Yes	Yes	Yes	Yes
Max Fluid Viscosity	40 wt.	40 wt.	40 wt.	40 wt.
Suction Tube	Telescoping PVC	Telescoping PVC	Telescoping PVC	Telescoping PVC
Non-Drip Tip	No	Yes	No	Yes (D01)
Powder Coat Finish	Yes	Yes	Yes	Yes
Seals	Buna N	Buna N	Buna N	Buna N
Threads on Spout	Garden Hose	Non-Drip Spout	Garden Hose	Non-Drip Spout

Available Accessories:

104006G



- Locking nut
- Allows 360° positioning on pump
- Fits all above models

D01



- Non-Drip Attachment
- 3/4" GHT

L30-99N



- Steel telescoping suction tube with foot valve
- Fits all above models

170

- Lever Lock
- Fits up to a 1/2" lock
- Fits most lever style drum pumps
- Lock not included



HAND PUMPS

Quart Stroke

Pumps Not Suitable for Flammable Liquids, Water Based Liquids, or Corrosive Liquids.

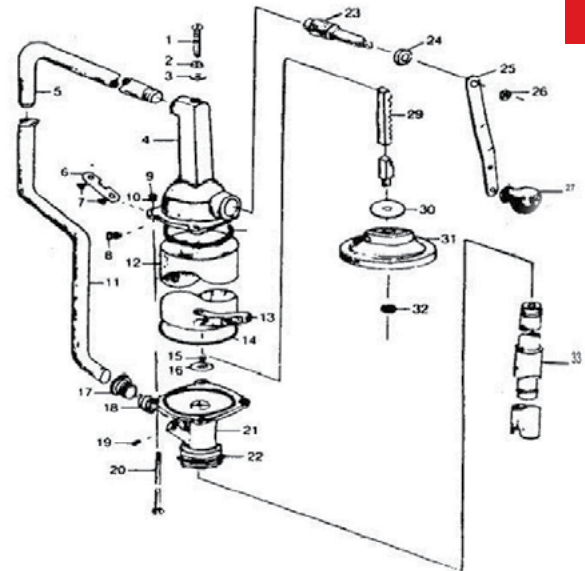

Ref. No.	Part No.	Description
1	975-005	Adjustment Screw
2	975-010	Jam Nut
3	975-015	Leather Washer
4	975-020	Top Casting
5	975-025	Discharge Spout
6	975-030	Rack Guide
7	104017	Rack Guide Screws
8	975-040	Dog Point Screw
9	975-045	Main Stud Nuts
10	104017	Main Stud Washers
11	975-055	Drain Tube
12	975-060	Cylinder
13	975-065	Lock Pin
14	975-070	Cylinder Gasket
15	104012	Check Valve Screw
16	975-080	Check Valve Washer
17	975-085	Bushing
18	975-090	Spring
19	975-095	Set Screw
20	975-100	Main Studs
21	975-105	Bottom Castings
22	104006	Locking Ring
23	975-115	Pinion
24	975-120	Pinion Seal
25	975-125	Crank Arm
26	975-130	Crank Locknut
27	975-135	Crank Knob
28	975-140	Crank Rivet
29	975-145	Rack
30	975-150	Piston Valve
31	975-155	Piston
32	975-160	Lock Nut
33	L30-99N	Suction Tube

Model	975
Container Size	15 to 55 gallon
Bung Size	2" NPT
Delivery	1-quart per cycle
Lockable Crank Arm	Yes
Suction Tube	Steel Telescoping
Seals	Delrin

HAND PUMPS

Lever Style



Pumps Not Suitable for Flammable Liquids, Water Based Liquids, or Corrosive Liquids.



155

- Fits 30 to 55-gallon drums



15-30

- Fits 15 to 30-gallon drums



336

- Fits 16-gallon open head drums



338

- Fits 15 to 55-gallon drums

Maximum 140-wt.

Model	Hose Assembly	Bung Adapter	Approximate Delivery	Seals
155	5' (104016-A)	2" (106025)	1-gal per 32 strokes	Buna N
15-30	5' (104016-A)	2" (106025)	1-gal per 32 strokes	Buna N
336	5' (104016-A)	Cover for Drum	1-gal per 32 strokes	Buna N
338	Not Included	2" (106025)	1-gal per 32 strokes	Buna N

HAND PUMPS

Premium Lever Style



1208

- Includes Pint meter (1500)
- Fits 16-gallon drum



1209

- Does **NOT** included meter
- Fits 16-gallon drum



1209RAR

- Pump and hose assembly only
- Fits 16 to 55-gallon drums

Features for all models:

- Recommended for oil with a viscosity of 5 to 130-wt.
- Double action pump (pumps fluid on the upward and downward stroke)
- Adjustable lever for varying oil viscosity
- First two holes near suction rod must be used for all lubes over 50-wt. Use last hole for maximum delivery
- Buna N seals
- Plated carbon steel construction
- Steel telescoping suction tube
- Bung adapter

Pumps Not Suitable for Flammable Liquids, Water Based Liquids, or Corrosive Liquids.

Model	1208	1209	1209RAR
Delivery	1-gal. per 32 strokes	1-gal. per 32 strokes	1-gal. per 32 strokes
Container Size	16-gallon drum	16 to 55-gallon drum	16-gallon drum
Discharge Hose	5' delivery hose	5' delivery hose	5' delivery hose
Drum Cover	680-823	680-823	None
Drum Dolly	120-S	120-S	None
Meter	Pint Meter (1500)	None	None

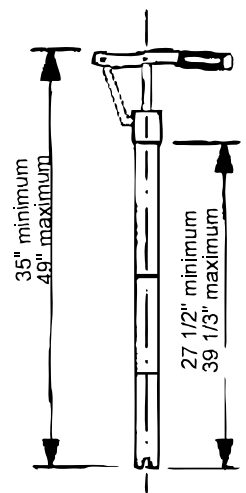

HAND PUMPS

Lift Style



Pumps Not Suitable for Water Based Fluids



366

- Fits 15 to 55-gallon drums
- Recommended for light oil products



366T

- Fits 15 to 55-gallon drums
- Recommended for paint thinners and some non-corrosive chemicals

Maximum 140-wt.

Model	366	366T
Delivery Rate	1-gallon per 6 lift strokes	1-gallon per 6 lift strokes
Container Size	15 to 55-gallon drum	15 to 55-gallon drum
Length	37 1/2"	37 1/2"
Seal	PTFE	PTFE
Bung Adapter	Powder Coated	Unpainted

Features both models:

- Plated steel construction with die cast aluminum head
- Heavy-duty bar stock handle
- Cast iron bung adapter for a durable long lasting thread
- Garden hose threads on the head of the pump allow for a threaded connection
- Brass piston ring allows for smooth operation without deterioration

WASTE OIL DRAINS

Low Profile Truck Drains



234

- For draining oil or antifreeze from heavy-duty trucks and RVs where a lift drain is not suitable
- Four 4" swivel casters provide excellent maneuverability
- Heavy-duty polyethylene construction
- 6' discharge hose with steel nozzle
- Black wire mesh screen
- 17-gallon capacity
- Dimensions: H- 7.50" W- 27.55" L- 43.30"
- *Ships freight only*



237

- For draining oil or antifreeze from heavy-duty trucks and RVs where a lift drain is not suitable
- Translucent body for easy viewing of fluid level
- Heavy-duty polyethylene
- 2 rear stationary wheels
- 2 large swivel casters
- 17-gallon capacity
- Wire screen
- Dimensions: H- 8" W- 25" L- 46"
- *Ships freight only*

Included Evacuation Kit (236):

- 115V UL Listed Pump
- Rubber discharge hose



227

- For draining oil or antifreeze from heavy-duty trucks and RVs where a lift drain is not suitable
- 18-gallon capacity
- Heavy-duty steel construction
- ½" NPT drain outlet
- Dimensions: H- 8" W- 25 ½" L- 47 ¼"
- *Ships freight only, 65lbs shipping weight*



(227)



1035K2

- Air operated suction kit for draining (227)
- Includes: pump, hoses, mounting bracket, and other necessary connections.
- For complete details, see Pg. 13

**1234**

- For gravity drain of fluids from engines, gearboxes, or differentials of all motor vehicles placed on an auto-lift or pit
- Adjustable neck with a minimum height of 53" and maximum height of 65"
- 21-gallon wheel mounted tank with front ball bearing wheels
- Centrally mounted bowl on swivel joint for positioning
- Level sight gauge: scaled in liters and gallons
- 6" x 8" x 2" removable steel tool tray

Model	1234
Collection Capacity	16-gallons (max)
Funnel	14" Diameter
Bowl	4-gallon adj. height
Draining PSI	7 PSI (Max)
Drain Hose	6 ½'
Tool Tray	6" x 8" x 2" Steel

**Features for (309), (316) & (318):**

- Translucent
- Durable polyethylene construction
- 18" polyethylene funnel (699J)
- 1 ¾" drain tube
- Adjusts from 44 ½" to 67" in height

Optional Accessories

- Drain Pan 24" x 24" (776)
- Darin Pan 24" x 37" (778)

Model	309	316	318
Capacity	8-gallon	8-gallon	18-gallon
Casters	No	Yes	Yes (3 ½")
Drain Valve	No	No	Yes
2" NPT Opening	No	No	Yes

**312**

- For converting 120lbs open head drum into a lift drain (*drum not included*)
- Fits 16-gallon or 120lbs open head containers
- Drum cover
- 67 ½" drain pipe
- 14" steel funnel

Optional Accessory

- Drum Dolly (120-S)

WASTE OIL DRAINS

Lift/Gravity Drains



OIL



1235

- 17 gallon wheel mounted tank
- Adjustable height with minimum 49" and maximum 69"

1236

- 23 gallon wheel mounted tank
- Adjustable height with minimum 55" and maximum 75"

Features for Both Models:

- Centrally mounted bowl on swivel joint for positioning
- Front and rear ball bearing wheels (3" front casters and 6" rear wheels)
- Level sight gauge: scale in liters and gallons
- Anti-splash screen/filter provides useful support for draining used filters

Model	1235	1236
Collection Capacity	13.7-gal (Max)	19.7-gal (Max)
Funnel	22 1/2" Diameter	22 1/2" Diameter
Bowl	3 1/2-gal adj. height	3 1/2-gal adj. height
Draining PSI	7 PSI (Max)	7 PSI (Max)
Drain Hose	6 1/2'	6 1/2'
Tool Tray	6" X 8" X 2" Steel	6" X 8" X 2" Steel

**1230**

- 23 gallon portable unit

1231

- 23 gallon portable unit with funnel

Features for Both Models:

- 2 heavy-duty 6" ball bearing rear wheels
- 2 front 3" ball bearing swivel casters
- Fluid level indicator
- Continuous connection to air source not required

Included probes; size and type:**Plastic**

- 1/4" X 27 1/2"
- 3/16" X 27 1/2"
- 5/16" X 27 1/2"
- 9/32" X 39 3/8"

Metal

- 1/4" X 27 1/2"
- 3/16" X 27 1/2"

Model	1230	1231
Tank Capacity	23-gal	23-gal
Min. Oil Temp	158° F (for suction)	
Draining PSI	7 PSI (Max)	7 PSI (Max)
Suction Hose	6 1/2' w/Probes	6 1/2' w/Probes
Drain Hose	6 1/2'	6 1/2'
Tool Tray	6" X 8" X 2" Steel	6" X 8" X 2" Steel

**1231**

WASTE OIL DRAINS

Pantograph Suction/Drainer

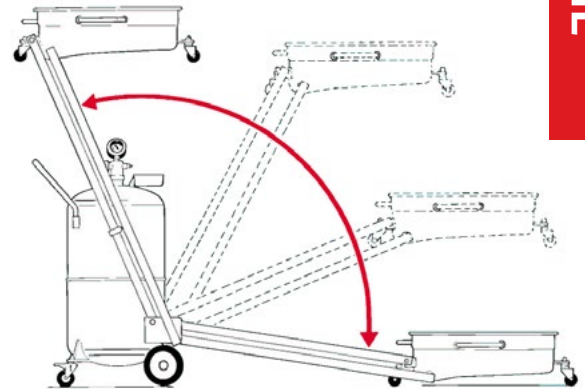

The pantograph arms allow the tank to be placed on the floor or raised, for draining under a lift.

Overall dimensions

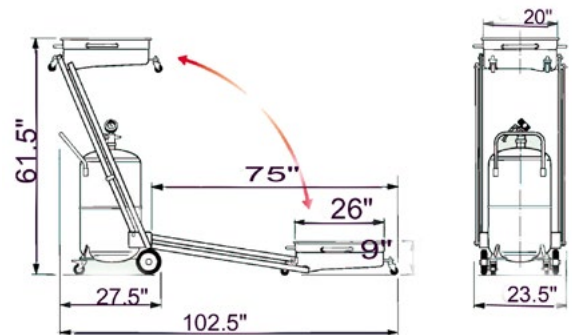

6215

- 30 gallon wheel mounted tank holds 25 gallons before draining
- Drains oil from heavy-duty trucks and RVs where a lift drain is not safely available
- Tank is equipped with level gauge and removable tool tray
- 13 gallon drain pan can be lowered to a height of 9" for rolling under cars and trucks

This versatile 3 in 1 oil suction/drainer can be used to change oil on all types of automobiles and trucks:

- 1) By gravity, with tank on the floor
- 2) By gravity with pan raised, with motor vehicles placed on auto lift or over a pit
- 3) By suction with probe inserted directly into the engine. A continuous connection to the compressed air line or other energy source is not required (the oil must be hot, 160-175° F)

Section Contents

Grease Equipment.....36-59

Oil Equipment Packages & Info37

Air Operated Grease Systems 38-42

50:1 Ratio Pump for 25-50lb Pail 38

60:1 Ratio Pump for 25-50lb Pail 39

65:1/50:1 Ratio Pump for 120lb Drum 40

60:1 Ratio Pump for 120lb Drum 41

Pumps for 400lb Drums 42

Grease Handles43

Follower Plates.....44

Hand Grease Pumps45

Bearing Packers.....46

Grease Gun Filler Pumps.....47

Grease Guns 48-53

19.2 Volt Cordless Grease Gun 48

Air Operated Grease Guns 49

Pistol Grip 50-51

Lever Style 52

Premium Grease Guns 53

Grease Gun Accessories 54-55

Hose Assemblies 54

Grease Tools 55

Grease Couplers56-57

Premium, Standard, and Heavy-Duty 56

Couplers and Adapters..... 57

Grease Fittings 58-59

Kits, Caps, and Feeders 58

Standard, Button Head, Metric Fittings and Tools..... 59

Grease Related Accessories

Hose Assemblies & Hose Reels 85-87

Drum Equipment 88-89

Air Controls 98

Industrial Cleaning Products 100



Packages & Information



Package # For 120lb drums	Pump	Reel
6167	65:1 (1213R less dolly)	52' (1440R)
6168	50:1 (1220R less dolly)	39' (1474R)

All packages include an air filter with nighttime drain, regulator, gauge, ball valve, quick disconnects (1559A-ASSY), and all connecting components.

NLGI Grade Comparison

NLGI Grade	Worked Penetration after 60 Strokes at 25°C (0.1mm)	Grease Consistency	Food Consistency Comparison
000	445-475	Fluid	Ketchup
00	400-430	Fluid	Applesauce
0	355-385	Very Soft	Brown Mustard
1	310-340	Soft	Tomato Paste
2	265-2995	Moderately Soft	Peanut Butter
3	220-250	Semi-Fluid	Vegetable Shortening
4	175-205	Semi-Hard	Frozen Yogurt
5	130-160	Hard	Smooth Pate
6	85-115	Very Hard	Cheddar Cheese Spread

AIR OPERATED GREASE SYSTEMS

50:1 Ratio Pump for 25-50lb Pail

50lb Pail Up To No.2 NLGI

GREASE



3574R

- Complete system with all parts shown for pumping grease from 5 to 6-gallon buckets and 25-50lb. pails



(3574R)

Model	3574R
Pump	Heavy-Duty 50:1
Max Grease NLGI	No. 2
Max Delivery	52oz per minute @ 90PSI
Max Air PSI	110 PSI
Air Consumption	4.59 CFM @ 100 PSI
Air Inlet	1/4" NPT
Air Hose	1/4" x 4' (2004)
Tube Length	16"
Pump Tube Diameter	1 3/16"
Airline Filter Package	1559A-ASSY

Available Packages:

Package #	Hose Length	Hose P/N
3574R	6'	1806
3574R-00	None	-
3574R-10	10'	1810
3574R-12	12'	1812
3574R-16	16'	1816
3574R-20	20'	1820
3574R-25	25'	1825



Included Accessories:



- 1559A-ASSY**
- Regulator combination unit



- 1536A**
- Control handle



- 66599**
- Carry handle



- 2004**
- 4' Air hose



- 65310**
- Drum Cover



- 1545**
- "Z" swivel



- 107016**
- Follower plate



- 1806**
- 6' Grease hose

AIR OPERATED GREASE SYSTEMS

60:1 Ratio Pump for 25-50lb Pail

50lb Pail Up To No.2 NLGI

3574A

- Complete system with all parts shown for pumping grease from 5 to 6-gallon buckets and 25-50lb. pails

Model	3574A
Pump	Heavy-Duty 60:1
Max Grease NLGI	No. 2
Max Delivery	2.42-lbs per minute @ 100PSI
Max Air PSI	145 PSI
Air Consumption	5.50 CFM @ 100 PSI
Air Inlet	1/4" NPT
Air Hose	1/4" x 4' (2004)
Tube Length	17 3/4"
Pump Tube Diameter	1 3/16"
Bung Adapter	2" (28591)
Airline Filter Package	1559A-ASSY



GREASE

Available Packages:

Package #	Hose Length	Hose P/N
3574A	6'	1806
3574A-10	10'	1810
3574A-12	12'	1812
3574A-16	16'	1816
3574A-20	20'	1820
3574A-25	25'	1825

Included Accessories:



1559A-ASSY
• Regulator combination unit



1536A
• Control handle



1806
• 6' Grease hose



2004
• 4' Air hose



18527
• Drum Cover



1545
• "Z" swivel



107016
• Follower plate



AIR OPERATED GREASE SYSTEMS

120lb Drum

65:1/50:1 Ratio Pump for 120lb Drum



Features for Both Models:

- Complete system with all parts shown for pumping grease from 120lb drums
- Suction tube constructed with no seals to eliminate excessive wear

GREASE



Model	1213R	1220R
Pump	Heavy-Duty 65:1	Heavy-Duty 50:1
Max Grease NLGI	No. 3	No. 2
Max Delivery	66oz per minute @ 90PSI	52oz per minute @ 90PSI
Max Air PSI	110 PSI	110 PSI
Air Consumption	8.74 CFM @ 100 PSI	4.59 CFM @ 100 PSI
Air Inlet	1/4" NPT	1/4" NPT
Air Hose	1/4" x 4' (2004)	1/4" x 4' (2004)
Pump Head Diameter	2 1/2"	2 1/2"
Head Length	10"	10"
Tube Length	29"	29"
Pump Tube Diameter	1 3/16"	1 3/16"
Airline Filter Package	1559A-ASSY	1559A-ASSY

Available Packages:

Package #	Hose Length	Hose P/N	Package #	Hose Length	Hose P/N
1213R	6'	1806	1220R	6'	1806
1213R-00	None	-	1220R-00	None	-
1213R-10	10'	1810	1220R-12	12'	1812
1213R-12	12'	1812	1220R-16	16'	1816
1213R-16	16'	1816			
1213R-20	20'	1820			
1213R-25	25'	1825			
1213R-50	50'	1850			

Applications:

- For dispensing most greases short and long distances
- Particularly suited for centralized dispensing system
- Highly recommended for specific needs requiring a higher quantity of grease and higher pressure

Included Accessories:



1559A-ASSY
• Regulator combination unit



1536A
• Control handle



1806
• 6' Grease hose



2004
• 4' Air hose



65385
• Drum Cover



1545
• "Z" swivel



1524
• Follower plate



120-S
• Drum dolly

AIR OPERATED GREASE SYSTEMS

60:1 Ratio Pump for 120lb Drum

120lb Drum Up To No. 2 NLGI



Model	1213A & 1214A
Pump	Heavy-Duty 60:1
Max Grease NLGI	No. 2
Max Delivery	2.42lbs per minute @ 100PSI
Max Air PSI	145 PSI
Air Consumption	5.50 CFM @ 100 PSI
Air Inlet	1/4" NPT
Air Hose	1/4" x 4' (2004)
Tube Length	29 1/2"
Pump Tube Diameter	1 5/32"
Bung Adapter	2" (28591)
Airline Filter Package	1559A-ASSY

1213A & 1214A:

- Complete system with all parts shown for pumping grease from 120lb drums



GREASE

Available Packages:

Package #	Hose Length	Hose P/N
1213A	6'	1806
1213A-00	None	-
1213A-10	10'	1810
1213A-12	12'	1812
1213A-16	16'	1816
1213A-20	20'	1820
1213A-25	25'	1825
1213A-50	50'	1850

1213A Included Accessories:



1559A-ASSY

- Regulator combination unit



1536A

- Control handle



1806

- 6' Grease hose



2004

- 4' Air hose



680-823

- Drum Cover



1545

- "Z" swivel



1524

- Follower plate



120-S

- Drum dolly

1214A Included Accessories:



1559A-ASSY

- Regulator combination unit



1806

- 6' Grease hose



2004

- 4' Air hose



680-823

- Drum Cover



1524

- Follower plate

AIR OPERATED GREASE SYSTEMS

400lb Drum

Pumps for 400lb Drums

GREASE

1212R

- Dispenses grease from a 400lb open head drum
- Durable steel pump head
- Air motor with a silicone lube to eliminate the need for an oiler



1559A-ASSY

- Air regulator combination unit

65600

- Drum Cover

66590

- Follower plate

Optional Accessories

- Hose reel (1440R)
- Booster control handle (1536A)
- "Z" swivel, for use with (1536A) control handle, (1545)
- Continuous flow control handle (1534)
- "Z" swivel, for use with (1534) control handle, (1547)
- Drum dolly (140-S, 140-SOR)

1212A

- Fits 400lb drum



1559A-ASSY

- Regulator combination unit



1806

- 6' Grease hose



2004

- 4' Air hose



18527

- Drum Cover



1524

- Follower plate

Model	1212R	1212A
Pump	Heavy-Duty 65:1	Heavy-Duty 60:1
Max Grease NLGI	No. 3	No. 2
Max Delivery	66oz per minute @ 100PSI	2.42lbs per minute @ 100PSI
Max Air PSI	110 PSI	145 PSI
Air Consumption	8.47 CFM @ 100 PSI	5.50 CFM @ 100 PSI
Air Inlet	1/4" NPT	1/4" NPT
Air Hose	1/4" x 4' (2004)	1/4" x 4' (2004)
Tube Length	37"	36 5/8"
Pump Tube Diameter	1 3/16"	1 5/32"
Bung Adapter	N/A	2" (28591)
Airline Filter Package	1559A-ASSY	1559A-ASSY

GREASE HANDLES

Continuous Flow and Booster Handles

Control Handles



1534

- Continuous flow
- Pressure is determined by the pump used with this handle



Pressure Relief Valve

1533

- Booster handle with pressure relief valve
- Each pull of the handle increases pressure up to 10,000 PSI

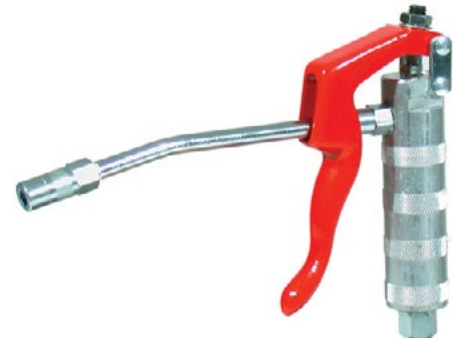

1536A

- Booster handle
- Each pull of the handle increases pressure up to 10,000 PSI

GREASE

Model	1533	1534	1536A
Inlet	1/8" NPT	1/4" NPT	1/8" NPT
Outlet	1/8" NPT	1/8" NPT	1/8" NPT
Continuous Flow	Yes	Yes	Yes
Grease Coupler	N/A	Standard 3-Jaw (28)	Heavy-Duty 3-Jaw (25)
Pressure Relief Valve	Yes	No	No
Construction	Steel	Steel	Aluminum

Accessories



1544

- Straight swivel
- Inlet: 1/4" NPT (F)
- Outlet: 1/4" NPT (M)
- Compatible with: 1534



1547

- "Z" Swivel
- Inlet: 1/4" NPT (F)
- Outlet: 1/4" NPT (M)
- Compatible with: 1534



1545

- "Z" Swivel
- Inlet: 1/4" NPT (F)
- Outlet: 1/8" NPT (M)
- Compatible with: 1533, 1536A



17

- Flexible hose assembly for use with control handles
- Includes adapter, hose, and coupler
- Working pressure 5,000 PSI
- Burst pressure 20,000 PSI

FOLLOWER PLATES

Straight or Tapered

Steel follower plates suitable for barrels, drums, and pails (straight or tapered).

GREASE



107012/107016



1524



18573

Part #	Description	Ideal For	I.D.	O.D.
For 25-50lb Pails				
107012	Flexible rubber edge	328 (Pg. 47)	1.50"	11.25"
107016	Flexible rubber edge	3574A (Pg. 39) 3574R (Pg. 38)	1.16"	11.375"
230000	1 ¼" Center rubber grommet	567 (Pg. 45)	1.25"	11.00"
For 120lb Drums				
1523	Steel edge	327 (Pg. 47)	1.437"	14.25"
1524	Flexible rubber edge	1213R (Pg. 40) 1220R (Pg. 40) 1213A (Pg. 41)	1.25"	15.00"
For 400lb Drums				
18573	Flexible rubber edge	1212A (Pg. 42)	1.175"	23.25"
66590	Flexible rubber edge	1212R (Pg. 42)	1.1875"	23.25"

HAND GREASE PUMPS



540

- Variable stroke develops up to 4,000 PSI
- Delivers 0.3oz per stroke
- 22lb steel container with carrying handle
- Heavy-duty cast iron pump
- 6 ½' high pressure hose with 4 jaw coupler
- Spring loaded follower plate
- Container must be used with this pump and bulk filled
- Recommended for grease up to NLGI No. 3



550

- Fits 25 to 50lb pails
- Maximum output pressure 3,500 PSI
- Delivers 1.2oz per 28 strokes
- 4 jaw coupler
- Follower plate (107016)
- 6' high pressure hose
- Carrying handle
- Easily dispense to a grease system
- Recommended for grease up to NLGI No. 2



567

Manual grease dispensing system including spring loaded pump, booster control handle, follower plate, and connecting hose. When installed on a 25 to 50lb pail (not included), each downstroke of the pump handle allows up to 3.2oz of grease to be dispensed through the booster handle.

The booster handle is a single shot style includes connecting hose, swivel, and a switch for high volume or high pressure.

- Fits 25 to 50lb pails
- Maximum output pressure 8,000 PSI
- Booster control handle
- Follower plate (107016)
- 9' low pressure hose
- Recommended for grease up to NLGI No. 2

BEARING PACKERS

Portable, Bench Type, Pails and Drums

Up To
No. 2
NLGI

Recommended For Packing Bearings with a Maximum 6" Diameter

GREASE



331

- Portable bearing packer with grease gun
- Non-threaded top cone for fast placement of bearings
- Dust cover
- Extended base
- Gun holder (149SP)
- Lever style grease gun (419)



333

- Grease pump and bearing packer for 25 to 50lb pails



343

- Grease pump and bearing packer for 120lb drums

Model	333	343
Delivery	Variable stroke, up to 1oz per stroke	Variable stroke, up to 1oz per stroke
Follower Plate	107012	1523
Pump Construction	Zinc Plated	Zinc Plated
Head Construction	Zinc Die Cast	Zinc Die Cast
Pump Length	18"	30"
Drum Cover Diameter	12" Powder Coated	16" Powder Coated
Collar	Adjustable	Adjustable



625

- Bench type
- For use with hand or air operated grease gun
- Non-threaded top cone for fast placement of bearings
- Dust cover
- Mounting base

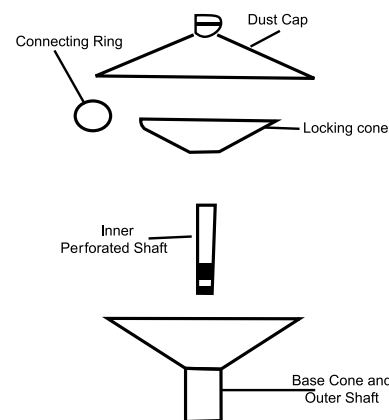

GREASE GUN FILLER PUMPS

For Filling From Drums and Pails

GREASE



327

- Fits 120lb drum
- Pump Length 30"
- Drum cover diameter 16"
- Steel edge follower plate (1523)



328

- Fits 25 to 50lb pails
- Pump length 18"
- Drum cover diameter 12"
- Rubber lined follower plate (107012)

Model	327 & 328
Delivery	Variable stroke, up to 1oz per stroke
Pump Construction	Zinc Plated
Head Construction	Die-cast Aluminum
Flange Construction	Cast Aluminum
Male Loader Nipple	80SP
Female Loader Nipple	29

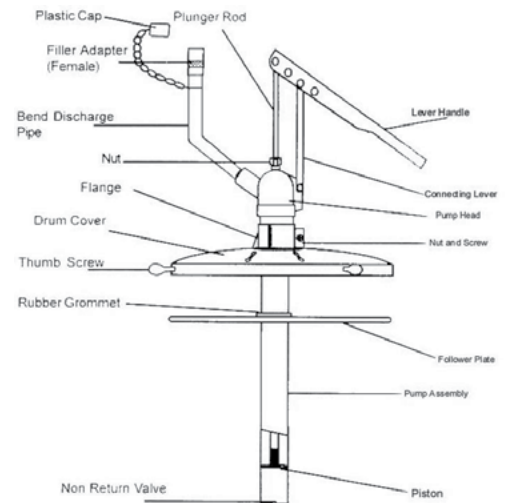

GREASE GUNS

Up To
No. 2
NLGI

19.2 Volt Cordless Grease Gun

GREASE



**BEST
SELLER**

(912-19)

912-19

- NiCad
- Includes 1 charger (91202-19)
- Includes 2 batteries (91201-19)

912-19L

- Lithium
- Includes 1 charger (91202-19L)
- Includes 1 battery (91201-19L)

Features For Both Models

- 19.2 volt cordless grease gun
- Recommended for grease up to NLGI No. 2 at minimum 50° F
- For delivery of grease in a variety of applications and hard to reach places
- Loading options: cartridge, suction, or bulk
- Max pressure: 8,500 PSI
- 30" whip hose with spring guard
- 1/8" NPT outlet threads
- 14 1/2 oz cartridge capacity
- Air bleeder valve
- Shoulder strap (91207-19)
- Hard plastic storage case

Shipping lithium batteries requires additional documents.

Scan QR Code

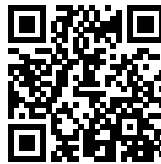

For Product Tour



912-19LK

- 19.2 volt NiCad to Lithium retro fit kit
- Convert ALL National-Spencer 912-19 NiCad grease guns to the NEW 19.2 volt lithium grease gun
- Lithium has 30% more power than NiCad
- Kit includes: 1 battery (91201-19L) and 1 charger (91202-19L)

Do Not Mix Batteries and Chargers. Only Use NiCad batteries with NiCad Chargers and Lithium Batteries with Lithium Chargers.



91201-19L

- Lithium Battery



91202-19L

- Lithium Charger



91203-19

- 12 volt car charger
- Only works with NiCad Battery



91204-19

- Grease tube warming blanket

GREASE GUNS

Air Operated Grease Guns



911

- Single Shot
- Male quick connect fitting

914

- Continuous Flow



Model	911 & 914
Max Outlet Pressure	4,000 PSI
Delivery	1.30oz per 40 shots
Inlet Pressure	75 to 100 PSI
Air Inlet	¼" NPT
Capacity	14 ½oz cartridge
Extension	6" steel (½" NPT)
Loading options	Cartridge, suction, bulk
Construction	Aluminum die cast head

GREASE

Mini Grease Gun



180

- Zinc plated grease gun with rigid extension for 3oz cartridges
- Single handed operation
- T grip plunger rod handle for firm grip
- Attractive clamshell packaging
- Incorporates two discharge ports: front discharge port for regular greasing applications and top port for lubrication of hard to reach fittings

Model	180 & 180G
Max Outlet Pressure	3,000 PSI
Coupler	4 Jaw with ball check
Capacity	3oz cartridge
Extension	4" steel (½" NPT)
Loading Options	Cartridge or suction
Construction	Textured zinc plated



180G

- 180 grease gun with (1) 3oz grease started cartridge included.

Accessories

16

- 12" flexible whip hose with 3 jaw coupler

35

- Bag of (3) 3oz tubes of lithium grease



GREASE GUNS

Pistol Grip

Up To
No. 2
NLGI

GREASE



610

- Zinc plated barrel
- 4" steel extension (59004)



619

- Powder coated barrel
- 4" steel extension (59004)



613

- Zinc plated barrel
- 12" whip hose (12R)



620

- Powder coated barrel
- 12" whip hose (12R)

Features for All Models

- Ergonomic pistol grip operation
- If gun fails to pump grease, unscrew the barrel from the head assembly one turn to release any air pockets.

Model	All Models
Max Outlet Pressure	5,000 PSI
Delivery	1oz per 40 strokes
Coupler	4 jaw (27)
Capacity	14 ½oz cartridge
Threads	⅛" NPT
Loading Options	Cartridge, suction, bulk
Loading Nipple	Optional (80SP)

GREASE GUNS

Pistol Grip



609

- Adjustable stroke, for higher pressure or more volume, grease gun with 18" whip hose and coupler

Model	609
Max Outlet Pressure	7,000 PSI
Delivery	1oz per 31 strokes
Capacity	14 ½oz cartridge
Loading options	Cartridge, suction, bulk

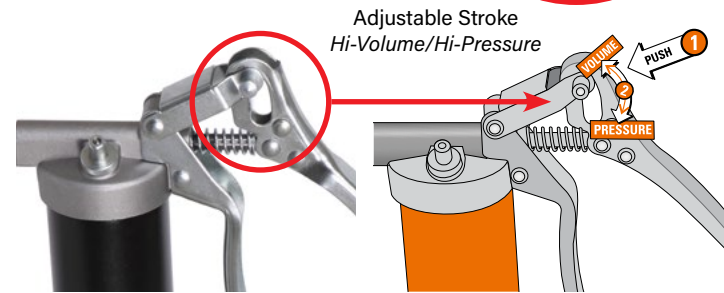

GREASE



615

- Chrome plated barrel
- 2 grease outlets
- Rigid 4" steel extension (1/8" NPT)

Model	609
Max Outlet Pressure	5,000 PSI
Delivery	1 ½oz per 40 strokes
Capacity	14 ½oz cartridge
Loading options	Cartridge, suction, bulk

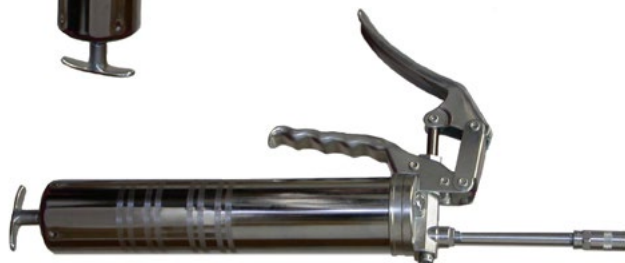

Accessories

149SP

- Grease gun holder

80SP

- Loader Nipple

12R

- 12" flex grease hose

33

- 14 ½oz grease cartridge

GREASE GUNS

Lever Style

Up To
No. 2
NLGI

GREASE



410

- Zinc plated barrel
- 5 ½" steel extension (55)
- Rubber grip



413

- Zinc plated barrel
- 12" flexible whip hose (12R)
- Rubber grip



414

- Die cast aluminum head
- Chrome plated finish
- 5 ½" steel extension (55)
- 12" flexible whip hose (12R)



415

- Die cast aluminum head
- Chrome plated finish
- 5 ½" steel extension (55)



419

- Red powder coated finish
- 5 ½" steel extension (55)



420

- Red powder coated finish
- 5 ½" steel extension (55)
- 12" flexible whip hose (12R)



444

- Die cast aluminum head
- Powder coated finish
- 5 ½" steel extension (55)

If gun fails to pump grease, unscrew the barrel from the head assembly one turn to release any air pockets.

Model	All Models
Max Outlet Pressure	7,000 PSI
Delivery	1oz per 28 strokes
Coupler	4 jaw (27)
Capacity	14 ½oz cartridge
Threads	½" NPT
Loading Options	Cartridge, suction, bulk

GREASE GUNS

Premium Grease Guns



HD4

- 5 1/2" steel extension (55)



HD4A

- 12" flexible whip hose (12R)

Features for Both Models

- Maximum pressure 10,000 PSI
- Soft rubber grip on lever handle for comfortable operation
- Heavy-duty cast iron head incorporates bulk loader nipple
- Short stroke for ease of use in confined spaces
- Delivers 1oz per 28 strokes
- Powder coated
- Holds 14 1/2oz cartridge or can be bulk loaded
- Hydraulic coupler (27)
- Loader nipple (80)
- Multiple loading options (cartridge, suction, or bulk)



GREASE

Grease Guns with Clear Grease Tubes

A clean and easy way to determine the type of grease you are dispensing when it matters.



620CTB

- 12" flexible whip hose (12R)
- Maximum pressure 5,000 PSI
- Delivers 1oz per 40 strokes

Color	Model
Silver	620CTS
Purple	620CTP
Black	620CTK
Green	620CTG
Gold	620CTY
Blue	620CTB
Red	620CTR



HD4ACTB

- 12" flexible whip hose (12R)
- Maximum pressure 10,000 PSI
- Delivers 1oz per 28 strokes

Color	Model
Silver	HD4ACTS
Purple	HD4ACTP
Black	HD4ACTK
Green	HD4ACTG
Gold	HD4ACTY
Blue	HD4ACTB
Red	HD4ACTR



Individual Tubes

- Clear grease tubes with anodized aluminum rings
- Fits all Zee Line grease guns and many other brands.

Color	Model
Silver	NS-CTS
Purple	NS-CTP
Black	NS-CTK
Green	NS-CTG
Gold	NS-CTY
Blue	NS-CTB
Red	NS-CTR

GREASE GUN ACCESSORIES

Hose Assemblies

GREASE

12R, 18R, & 19R

- Premium quality whip hose for hand operated grease guns.
- Offers maximum flexibility and long lasting construction.
- Rubber construction - inner tubing is Polyamide with polyurethane sheathing, reinforced diagonally in high tear resistant polyester.
- 1/8" NPT plated steel fittings



12R-SP

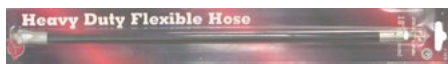

18R-SP

Hoses with a Max PSI rating below 5,000 PSI are intended for manual use only.

Hoses with a Max PSI rating above 5,000 PSI can be used with Air Operated greasing equipment.

Model	Description	Max PSI
12R	12" x 13/32"	5,800 PSI
12R-1	12" x 13/32" In poly bag	5,800 PSI
12R-SP	12" x 13/32" Blister packed	5,800 PSI
13R	12" x 13/32" 2 wire braid	6,000 PSI
18R	18" x 13/32"	5,800 PSI
18R-1	18" x 13/32" In poly bag	5,800 PSI
18R-SP	18" x 13/32" Blister packed	5,800 PSI
18RR	18" x 13/32" 2 wire braid	6,000 PSI
19R	24" x 13/32"	5,800 PSI
19R-SP	24" x 13/32" Skin packed	5,800 PSI
36R	36" x 13/32"	3,000 PSI
36R-SP	36" x 13/32" Skin packed	3,000 PSI



Flexible Position



Rigid Position



11SP

- Flexible and rigid extension adapter
- Maximum working pressure 5,000 PSI
- Allows operator to switch from flexible to rigid extension with one hand
- Overall length 13"
- 1/8" NPT (M)

GREASE GUN ACCESSORIES

Grease Tools

186

- Hand operated grease fitting cleaner
- For unstopping clogged grease fittings
- Plated finish with steel body
- 4 jaw grease coupler (27)
- Includes 5" flexible whip hose
- Replaceable o-ring
- Skin packaged
- Grip guard



GREASE



660

- Quick coupler lube kit
- For efficient connection and replacement of hand operated grease gun tips
- Quick connects are included with all tools
- Attractive and durable nylon pouch

Included Connections

- Stainless steel needle 1 1/2" long
- Lube adapter, 90° angle
- Needle nose adapter with .046 diameter tip
- Professional recessed lube adapter 3 1/4" long
- 12" hose with coupler and spring guard



Grease Gun
Not Included

33

- Multi-Purpose lithium grease cartridge
- 14 oz



149SP

- Grease gun holder



159

- Premium grease gun holder
- Extra secure
- Ideal for truck or tractor mounting
- Easy one hand operation



GREASE COUPLERS

Premium, Standard, and Heavy-Duty

GREASE



25, 27, & 28

- Sold in 10 unit increments

25SP, 27SP, & 28SP

- Blister packaged on a hanging card ready for display

Model	25	27	28
Max PSI	10,000 PSI	6,000 PSI	6,000 PSI
Description	Heavy-duty 3 jaw hydraulic coupler with ball check	Standard 4 jaw hydraulic coupler with ball check	Standard 3 jaw hydraulic coupler with ball check
OD	.670"	.590"	.590"



44

- 15,000 PSI
- Heavy-duty 3 jaw hydraulic coupler with ball check
- For air operated equipment
- OD: .662"



47SP

- 1,000 PSI
- Right angled hydraulic coupler
- Blister packaged



48

- 360° swivel coupler
- Also comes in Blister Pack (48SP)



52

- 7,000 PSI
- Zinc plated swivel coupler
- Locks at 45° for easy access to most grease fittings
- Also comes in Blister Pack (52SP)

Premium Coupler

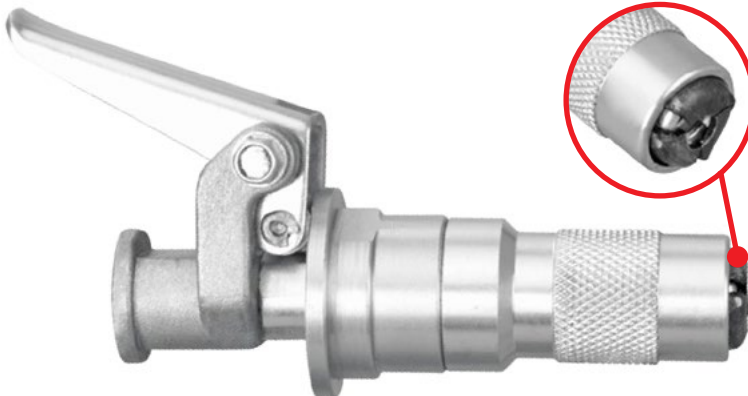

100

- No more broken grease nipples due to disconnecting the couplers.
- Quick dis-connect/locking grease coupler
- Hands free and leak proof greasing
- 8,000 PSI

