

Photos are not actual size

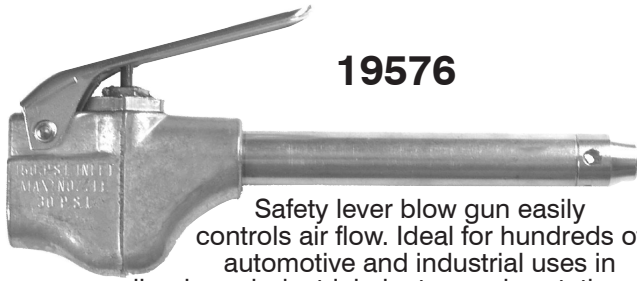

19576

Safety lever blow gun easily controls air flow. Ideal for hundreds of automotive and industrial uses in small or large industrial plants, service stations, garages, etc. Zinc alloy and brass construction. Meets OSHA 150 PSI Inlet, Max. Nozzle 30 PSI SCFM 10.0 @ 100 PSI. 1/4" NPT air inlet.

UNIT PACKAGE: 1

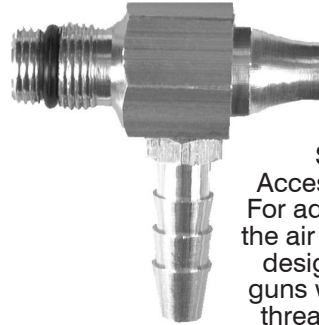

19578

Siphon Spray Nozzle. Accessory for 19577 Blow Gun. For adding moisture or solvent to the air stream. Unique dual thread design permits use on all blow guns with 7/16"-27 and 1/8" NPS threads. O-ring seal creates an air-tight assembly. Aluminum body construction.

UNIT PACKAGE: 1



19577

Compact safety lever blow gun. Includes a safety nozzle and a non-safety rubber tip nozzle. Features an easy to use hang-up hook. Chrome plated zinc alloy construction. Meets OSHA 150 PSI Inlet, Max. Nozzle 30 PSI. Safety tip SCFM 11.7 @ 100 PSI. Non-safety tip 12.9 @ 100 PSI. 1/4" NPT air inlet

UNIT PACKAGE: 1

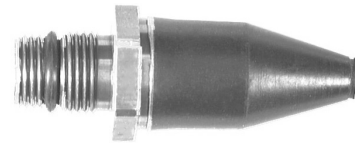

19579

Rubber Blow Gun Tip. Accessory for 19577 Blow Gun. For positive leak-proof connection when blowing out any fluids where a metal tip could mar the finish. Unique dual thread design permits use on all blow guns with 7/16"-27 and 1/8" NPS threads. O-ring seal creates an air-tight assembly. Brass body construction.

UNIT PACKAGE: 2

Clear Flexible Vinyl (PVC)

Our tubing has a broad range of chemical resistance to acids, alkalis and solvents. It's ideal for use in industrial air pressure line applications, in the food industry (FDA approved), for potable water, and for various gases and chemicals. Not for use with gasoline.



The Clear Flexible Tubing can be used with our connectors which are cataloged on page 200. The tubing can also be installed with our Hose Clamps (refer to the alphabetical index).

| Auveco Part No. | I.D. | O.D. | Wall Thickness | *Maximum Suggested Working Pressure (PSI @ 70 F) | Unit Pkg. |
|-----------------|-------|-------|----------------|--|-----------|
| 14801 | 1/8" | 1/4" | 1/16" | 59 | 100 Ft. |
| 14802 | 3/16" | 5/16" | 1/16" | 51 | 100 Ft. |
| 14803 | 1/4" | 3/8" | 1/16" | 51 | 100 Ft. |
| 14804 | 5/16" | 7/16" | 1/16" | 48 | 100 Ft. |
| 14805 | 3/8" | 1/2" | 1/16" | 41 | 100 Ft. |
| 14807 | 1/2" | 5/8" | 1/16" | 28 | 100 Ft. |
| 14808 | 1/2" | 3/4" | 1/8" | 41 | 100 Ft. |

*We recommend verification by testing of the size and material to be used.

Red Air Hose

Photo not actual size



Male Brass Fitting

Four spiral reinforced EPDM rubber construction offers superior durability and excellent flexibility. Limited oil resistance. Coupled with brass fittings. Maximum working pressure is 300 P.S.I.

| Auveco Part No. | I.D. | Description | Unit Pkg. |
|-----------------|------|--------------------------------|-----------|
| | | Impact Tool Air Hose | |
| 15538 | 3/8" | 1/4" Male Pipe Thread Fittings | 25' Roll |
| 15539 | 3/8" | 1/4" Male Pipe Thread Fittings | 50' Roll |

Black O.E.M. Heater Hose



Meets or exceeds SAE20R3 specifications. O.E.M. grade EPDM hose that withstands the abuse of corrosive additives, heat, cold, ozone, weather and abrasion

| Auveco Part No. | I.D. | Unit Pkg. |
|-----------------|------|-----------|
| 15540 | 1/2" | 50' Roll |
| 15541 | 5/8" | 50' Roll |
| 15542 | 3/4" | 50' Roll |

Vacuum and Windshield Washer Tubing



Meets SAE J1037 Type 2 Specifications EPDM Rubber

| Auveco Part No. | I.D. | O.D. | Description | Unit Pkg. |
|-----------------|-------|--------|-------------------|-----------|
| 4453 | 7/64" | 9/32" | Fits 1/8" Nipple | 25' |
| 4454 | 7/64" | 9/32" | Fits 1/8" Nipple | 50' |
| 4456 | 5/32" | 5/16" | Fits 3/16" Nipple | 25' |
| 4457 | 5/32" | 5/16" | Fits 3/16" Nipple | 50' |
| 4459 | 7/32" | 13/32" | Fits 1/4" Nipple | 25' |
| 4460 | 7/32" | 13/32" | Fits 1/4" Nipple | 50' |
| 4462 | 9/32" | 15/32" | Fits 5/16" Nipple | 25' |
| 4463 | 9/32" | 15/32" | Fits 5/16" Nipple | 50' |

For a complete listing of Barbed Brass Fittings see page 238.

Electronic Fuel Injection Hose



Meets or exceeds SAE 30R9 specifications. Quality fluoroelastomer tube and CM cover handles virtually every fuel on the market. Burst strength exceeds 900 PSI. 180 PSI working pressure

| Auveco Part No. | Size | Use with Auveco Clamp No. | Unit Pkg. |
|-----------------|------------------------|---------------------------|-----------|
| 19271 | 1/4" I.D. x 1/2" O.D. | 15860 | 10 ft. |
| 19272 | 5/16 I.D. x 9/16" O.D. | 15861 | 10 ft. |
| 19273 | 3/8" I.D. x 5/8" O.D. | 15862 | 10 ft. |



Fuel Line Hose

Not for Electronic Fuel Injection

Meets the following O.E.M. Specifications: GM: 6165-M • SAE J30R7 • Chrysler MSEA219

Auveco Fuel Line Hose is of the highest quality and meets all O.E.M. specifications. It has a special chemical resistant interior, a single braid, and a neoprene exterior for maximum life and durability. For temperature range from -29°F to 257°F.

Auveco Hose is designed for gas and diesel fuel lines (except Electronic Fuel Injection), emission control devices, and crankcase ventilation. In addition to the automotive applications, this hose is widely used on lawn mowers, marine motors, tractors and construction equipment to mention only a very few.

| Auveco Part No. | Size | Working Pressure | Unit Pkg. |
|-----------------|--------------------------|------------------|-----------|
| 17085 | 3/16" I.D. x 13/32" O.D. | 50 PSI | 25' |
| 4464 | 1/4" I.D. x 1/2" O.D. | 50 PSI | 25' |
| 4465 | 1/4" I.D. x 1/2" O.D. | 50 PSI | 50' |
| 4466 | 5/16" I.D. x 9/16" O.D. | 50 PSI | 25' |
| 4467 | 5/16" I.D. x 9/16" O.D. | 50 PSI | 50' |
| 4468 | 3/8" I.D. x 5/8" O.D. | 35 PSI | 25' |

For a complete listing of Barbed Brass Fittings see page 292.

20900
Hose Cutter



Razor sharp blade cleanly cuts heater hoses, fuel line hoses and any other type of flexible hose up to 1-1/4" diameter. The stainless steel blade is reversible for double the life. The pliers are made of glass-filled gray nylon for strength. Includes a locking hoop for safe storage. Overall length: 9-1/2"

UNIT PACKAGE: 1

SOLDERLESS TERMINALS

Nylon Insulated • Our Finest

Nylon Insulated with Insulation Grip

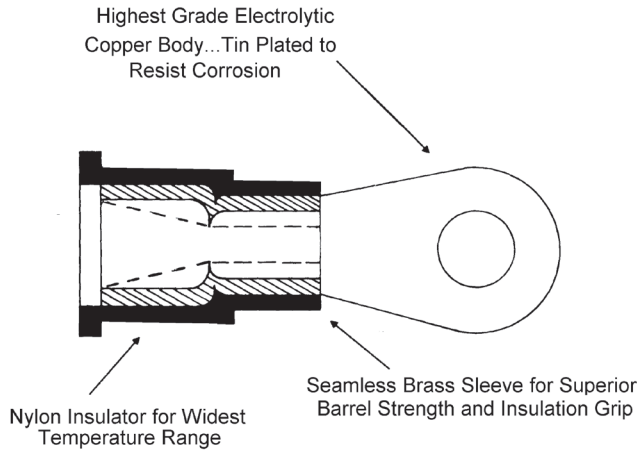

- Superior vibration resistance with insulated grip
- Superior barrel strength
- Constructed to meet the highest military and industrial standards

22-18 Gauge Wire Range (Red)

| Actual Size | Stud Size | Auveco Part No. | Unit Pkg. |
|-------------|----------------|-----------------|------------|
| | #4 - #6 | 12149 | 25 |
| | #8 - #10 | 12150 | 25 |
| | #12 - 1/4" | 17041 | 50 |
| | #8 - #10 | 12163 | 25 |
| | #4 - #6 | 12164 | 25 |
| | Butt Connector | 5791 16487 | 50 1000 |

16-14 Gauge Wire Range (Blue)

| Actual Size | Stud Size | Auveco Part No. | Unit Pkg. |
|-------------|------------|-----------------|-----------|
| | #4 - #6 | 9052 | 25 |
| | #8 - #10 | 9055 | 25 |
| | #12 - 1/4" | 9056 | 25 |

16-14 Gauge Wire Range (Blue)

| Actual Size | Stud Size | Auveco Part No. | Unit Pkg. |
|-------------|---------------------------|-----------------|------------|
| | 1/4" - 5/16" | 9057 | 25 |
| | 5/16" - 3/8" | 9058 | 25 |
| | #4 - #6 | 9059 | 25 |
| | #8 - #10 | 9060 | 25 |
| | #8 - #10 | 9064 | 25 |
| | Butt Connector | 5792 16488 | 50 1000 |
| | 1/4" Female Quick Connect | 12148 | 25 |
| | 1/4" Male Quick Connect | 12147 | 25 |

12-10 Gauge Wire Range (Yellow)

| Actual Size | Stud Size | Auveco Part No. | Unit Pkg. |
|-------------|----------------|-----------------|-----------|
| | #8 - #10 | 12151 | 25 |
| | #12 - 1/4" | 12152 | 25 |
| | 5/16" - 3/8" | 12153 | 25 |
| | #8 - #10 | 12162 | 25 |
| | Butt Connector | 5793 16489 | 50 500 |

SOLDERLESS TERMINALS

Vinyl Insulated • Copper • Electro Tin Plated
 For an assortment of Solderless Terminals see the Fix-Kits in the green pages

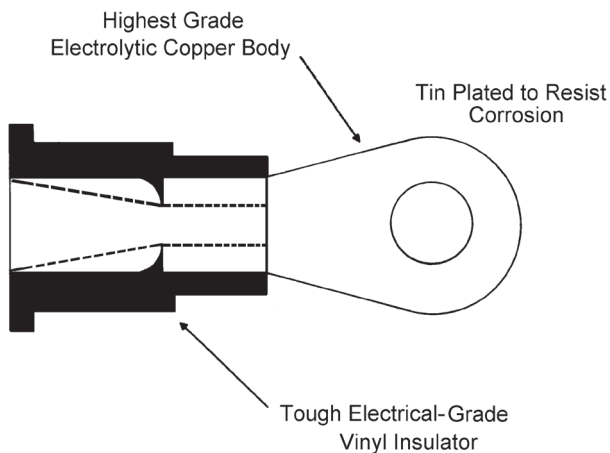

- Funnel barrel for easy wire insertion
- Friction groove in barrel resists wire pullout
- Heat treated for maximum strength

22-18 Gauge Wire Range (Red)

| Actual Size | Stud Size | Auveco Part No. | Unit Pkg. |
|-------------|--|-----------------|-------------|
| | #4 - #6 | 5021 | 100 |
| | #8 - #10 | 5023 | 100 |
| | #12 - 1/4" | 17040 | 50 |
| | #4 - #6 | 5033 | 100 |
| | #8 - #10 | 5034 | 100 |
| | #4 - #6 | 5038 | 100 |
| | Butt Connector | 5047 16484 | 100 1000 |
| | Closed End Butt Connector 22-14 Ga. | 9065 | 100 |

16-14 Gauge Wire Range (Blue)

| Actual Size | Stud Size | Auveco Part No. | Unit Pkg. |
|-------------|-----------|-----------------|-----------|
| | #4 - #6 | 5024 | 100 |
| | #8 - #10 | 5026 | 100 |

16-14 Gauge Wire Range (Blue)

| Actual Size | Stud Size | Auveco Part No. | Unit Pkg. |
|-------------|--|-----------------|-------------|
| | #12 - 1/4" | 5027 | 100 |
| | 5/16" - 3/8" | 12144 | 25 |
| | #4 - #6 | 5035 | 100 |
| | #8 - #10 | 5036 | 100 |
| | #8 - #10 | 5040 | 100 |
| | Butt Connector | 5048 16485 | 100 1000 |
| | Closed End Butt Connector 16-10 Ga. | 5072 | 100 |

12-10 Gauge Wire Range (Yellow)





| Actual Size | Stud Size | Auveco Part No. | Unit Pkg. |
|-------------|--------------|-----------------|-----------|
| | #8 - #10 | 5028 | 100 |
| | #12 - 1/4" | 5029 | 100 |
| | 1/4" - 5/16" | 5030 | 100 |
| | 5/16" - 3/8" | 5031 | 100 |
| | 7/16" - 1/2" | 5032 | 100 |

SOLDERLESS TERMINALS

Vinyl Insulated • Copper - Electro Tin Plated

For an assortment of Solderless Terminals see the Fix-Kits in the green pages

12-10 Gauge Wire Range (Yellow)

| Actual Size | Stud Size | Auveco Part No. | Unit Pkg. |
|---|-----------------|-----------------------------|------------|
|  | #8 - #10 | 5037 | 100 |
|  | #8 - #10 | 5041 | 100 |
|  | Butt Connector | 5049 16486 | 100 500 |
|  | 3-Way Connector | 5056 | 25 |



8 Gauge Wire Range (Red)

| Actual Size | Stud Size | Auveco Part No. | Unit Pkg. |
|---|----------------|-----------------|-----------|
|  | #12 - 1/4" | 17042 | 25 |
|  | 1/4" - 5/16" | 17043 | 25 |
|  | 5/16"-3/8" | 17044 | 25 |
|  | 7/16" - 1/2" | 17045 | 15 |
|  | Butt Connector | 17037 | 10 |

6 Gauge Wire Range (Blue)

| Actual Size | Stud Size | Auveco Part No. | Unit Pkg. |
|--|----------------|-----------------|-----------|
|  | #12 - 1/4" | 17046 | 15 |
|  | 1/4" - 5/16" | 17047 | 15 |
|  | 5/16" - 3/8" | 17048 | 15 |
|  | 7/16" - 1/2" | 17049 | 10 |
|  | Butt Connector | 17038 | 10 |

4 Gauge Wire Range (Yellow)

| Actual Size | Stud Size | Auveco Part No. | Unit Pkg. |
|--|----------------|-----------------|-----------|
|  | 5/16"-3/8" | 17052 | 10 |
|  | Butt Connector | 17039 | 10 |







Quick-Connect Terminals

1/4" Female Terminals Vinyl Insulated

| Actual Size | Wire Size | Auveco Part No. | Unit Pkg. |
|---|-----------|-----------------|-----------|
|  Red | 22-18 Ga. | 12155 | 25 |
|  Blue | 16-14 Ga. | 5068 | 100 |
|  Yellow | 12-10 Ga. | 12157 | 25 |

Quick-Connect Terminals

Fully Insulated Nylon Mating 1/4" Quick-Connects

| Actual Size | Wire Size | Auveco Part No. | Unit Pkg. |
|---|-----------------------|-----------------|-----------|
|  | 22-18 Ga. Female Red | 11827 | 50 |
|  | 22-18 Ga. Male Red | 11828 | 50 |
|  | 16-14 Ga. Female Blue | 11606 | 50 |
|  | 16-14 Ga. Male Blue | 11605 | 50 |
|  | 12-10 Ga. Female | 11829 | 25 |
|  | 12-10 Ga. Male Yellow | 11830 | 25 |





Quick-Connect Terminals

1/4" Male Tabs • Vinyl Insulated

| Actual Size | Wire Size | Auveco Part No. | Unit Pkg. |
|---|-----------|-----------------|-----------|
|  Red | 22-18 Ga. | 12154 | 25 |
|  Blue | 16-14 Ga. | 5067 | 100 |
|  Yellow | 12-10 Ga. | 12156 | 25 |



Quick-Connect Terminals

.187 (3/16") Sizes • Vinyl Insulated

| Actual Size | Wire Size | Auveco Part No. | Unit Pkg. |
|---|------------------------|-----------------|-----------|
|  | 22-18 Ga. Male | 17462 | 25 |
|  | 22-18 Ga. Female | 12159 | 25 |
|  | 16-14 Ga. Male, Blue | 12165 | 25 |
|  | 16-14 Ga. Female, Blue | 8781 | 50 |

Piggyback Terminals

1/4" Female • Fully Insulated Nylon

| Actual Size | Wire Range | Auveco Part No. | Unit Pkg. |
|---|-------------------------------------|-----------------|-----------|
|  | 22-18 Ga. 1/4" Tab Std. Barrel Red | 19298 | 15 |
|  | 16-14 Ga. 1/4" Tab Std. Barrel Blue | 19299 | 15 |



Fully Insulated Tap Disconnect

Mates with 11828, 11605 & 11830

| Wire Range | Auveco Part No. | Unit Pkg. |
|------------------|-----------------|-----------|
| 22-18 Ga. (Red) | 12791 | 10 |
| 18-14 Ga. (Blue) | 12161 | 10 |
| 12 Ga. (Yellow) | 14898 | 100 |
| | 12792 | 10 |

Fully insulated connectors are for tapping into a line without stripping the insulation. No special tools are required.

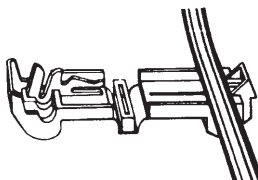

Place wire to be tapped in locating notch. Then close with pliers.

Complete connection with Auveco fully insulated male terminal: 11828 (22-18 Ga.), 11605 (16-14 Ga.) or 11830 (12 Ga.)

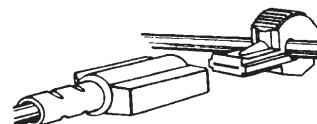



12158
Vinyl Insulated
Specialty Terminal
Wire Range: 1/4" Tab
Gauge: 16-14
UNIT PACKAGE: 25



17686
Mini Fuse Blade Type Fuse Tap
For tapping "hot side" of
mini fuse type fuse block
Refer to page 234
UNIT PACKAGE: 50





14474
Blade Type Fuse Tap
For tapping "hot side" of fuse block
Refer to page 173
UNIT PACKAGE: 25



11405
Fuse Block Accessory Clip
For add-on electrical equipment
UNIT PACKAGE: 50

SNAP PLUGS AND CONNECTORS

Snap Plugs • 22-18 Gauge Universal • .157" Diameter

| Actual Size | Description | Auveco Part No. | Unit Pkg. |
|--|------------------------------|-----------------|-----------|
|  | Vinyl Insulated | 11604 | 50 |
|  | Insulated Crimp-on Female | 10720 | 10 |

Mates with 11604

Snap Plugs • 16-14 Gauge Universal • .157" Diameter Use with 10719 Connector

| Actual Size | Description | Auveco Part No. | Unit Pkg. |
|---|-----------------|-----------------|-----------|
|  | Vinyl Insulated | 5063 | 100 |
|  | Nylon Insulated | 12146 | 25 |

Snap Plugs • 16-14 Gauge Ford (American & Lucas) • .176" Dia. Use with 11602 Connector

| Actual Size | Description | Auveco Part No. | Unit Pkg. |
|---|-----------------|-----------------|-----------|
|  | Vinyl Insulated | 5062 | 100 |

Fully Insulated Crimp-On Female (.157")

| Actual Size | Description | Auveco Part No. | Unit Pkg. |
|---|--------------------|------------------------------|-----------|
|  | Nylon 16-14 Ga. | 10719 17494 | 10 25 |

Mates with 5063 & 12146

Fully Insulated Crimp-on Female (.176")

| Actual Size | Description | Auveco Part No. | Unit Pkg. |
|--|--------------------|------------------------------|-----------|
|  | Nylon 16-14 Ga. | 11602 17493 | 25 50 |



Mates with 5062 & 12145

Snap Plug Tap-Disconnect Use Universal Snap Plugs (left column)

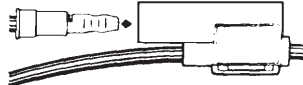
| Actual Size | Description | Auveco Part No. | Unit Pkg. |
|--|-------------|-----------------|-----------|
|  | 18-14 Ga. | 10319 | 10 |

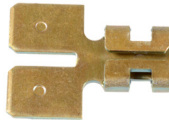

Dual Male-Female Adapter

| Actual Size | Description | Auveco Part No. | Unit Pkg. |
|--|---|-----------------|-----------|
|  | Converts .250" x .032" Male Tab to 2 Male Tabs | 8009 | 100 |
|  | Converts .250" x .032" Male Tab to 2 Male Tabs | 8788 | 25 |

KRIMP & SEAL TERMINALS

Special polyolefin tubing when heated terminal shrinks with a 3-1 ratio to completely seal entire connection, making penetration by any foreign material impossible.







24-22 Gauge Wire Range (Clear)

| Actual Size | Wire Size | Auveco Part No. | Unit Pkg. |
|---|----------------|-----------------|-----------|
|  | Butt Connector | 21317 | 10 |







22-18 Gauge Wire Range (Red)

| Actual Size | Wire Size | Auveco Part No. | Unit Pkg. |
|--|----------------|------------------------------|-----------|
|  | #6 | 13656 | 10 |
|  | #10 | 13657 | 10 |
|  | Butt Connector | 13659 19258 | 10 25 |
|  | .250" Female | 13660 | 10 |
|  | .250" Male | 13661 | 10 |
|  | #10 | 13658 | 10 |







16-14 Gauge Wire Range (Blue)

| Actual Size | Wire Size | Auveco Part No. | Unit Pkg. |
|--|-----------------|------------------------------|-----------|
|  | #6 | 13662 | 10 |
|  | #10 | 13663 | 10 |
|  | 1/4" | 13664 | 10 |
|  | 5/16" | 13665 | 10 |
|  | 3/8" | 13666 | 10 |
|  | Butt Connection | 13669 19259 | 10 25 |

16-14 Gauge Wire Range (Blue)

| Actual Size | Wire Size | Auveco Part No. | Unit Pkg. |
|--|--------------|------------------------------|-----------|
|  | .157" | 13681 | 10 |
| Mates with 13682 | | | |
|  | .157" | 13682 | 10 |
| Mates with 13681 | | | |
|  | .250" | 13670 | 10 |
|  | .250" | 13671 | 10 |
|  | .250" Female | 13672 19260 | 10 25 |
|  | .250" Male | 13673 19261 | 10 25 |

12-10 Gauge Wire Range (Yellow)

| Actual Size | Wire Size | Auveco Part No. | Unit Pkg. |
|--|----------------|------------------------------|-----------|
|  | #10 | 13674 | 10 |
|  | 1/4" | 13675 | 10 |
|  | 3/8" | 13676 | 10 |
|  | Butt Connector | 13678 19262 | 10 25 |
|  | #10 | 13677 | 10 |
|  | .250" Female | 13679 | 10 |
|  | .250" Male | 13680 | 10 |

Crimped for mechanical reliability, soldered for superior strength and conductivity, and sealed with heat shrink tubing for maximum durability.

Crimp Connector

- Crimp indicators show where the installation tool should be positioned
- Wire-stops in butt connectors prevent over-insertion of the wire
- Window in the connector allows for visual inspection & solder to flow into

Solder

- Flux coating to clean metal surfaces
- Low-temperature solder alloy for ease of installation
- Pre-measured solder to provide the right amount of solder ensuring a solid termination









Heat Shrink Tubing

- Adhesive lined polyolefin to seal the connection
- Translucent tubing to allow for visual inspection









24-22 Gauge Wire Range (Clear)

| Actual Size | Wire Size | Auveco Part No. | Unit Pkg. |
|---|----------------|-----------------|-----------|
|  | Butt Connector | 21002 | 10 |





20 - 18 Gauge Wire Range (Red)

| Actual Size | Wire Size | Auveco Part No. | Unit Pkg. |
|---|---|-----------------|-----------|
|  | #8 | 21260 | 10 |
|  | #10 | 21261 | 10 |
|  | 1/4" | 21262 | 10 |
|  | 5/16" | 21263 | 10 |
|  | 3/8" | 21264 | 10 |
|  | 1/4" Female Slip-On | 21278 | 10 |
|  | 1/4" Male Slip-On | 21279 | 10 |
|  | Butt Connector | 21003 | 10 |
|  | 24 - 22 Ga. to 20 - 18 Ga. Step down butt connector | 21275 | 10 |





16 - 14 Gauge Wire Range (Blue)

| Actual Size | Wire Size | Auveco Part No. | Unit Pkg. |
|--|---|-----------------|-----------|
|  | #8 | 21265 | 10 |
|  | #10 | 21266 | 10 |
|  | 1/4" | 21267 | 10 |
|  | 5/16" | 21268 | 10 |
|  | 3/8" | 21269 | 10 |
|  | 1/4" Female Slip-On | 21280 | 10 |
|  | 1/4" Male Slip-On | 21281 | 10 |
|  | Butt Connector | 21004 | 10 |
|  | 20-18 Ga. to 16-14 Ga. Step down butt connector | 21276 | 10 |

12 - 10 Gauge Wire Range (Yellow)

| Actual Size | Wire Size | Auveco Part No. | Unit Pkg. |
|--|-----------|-----------------|-----------|
|  | #8 | 21270 | 10 |
|  | #10 | 21271 | 10 |
|  | 1/4" | 21272 | 10 |
|  | 5/16" | 21273 | 10 |

Sealed Crimp & Solder Terminals
Continued 12 - 10 Gauge Wire Range (Yellow)

| Actual Size | Wire Size | Auveco Part No. | Unit Pkg. |
|--|---|-----------------|-----------|
|  | 3/8" | 21274 | 10 |
|  | 1/4" Female Slip-On | 21282 | 10 |
|  | 1/4" Male Slip-On | 21283 | 10 |
|  | Butt Connector | 21005 | 10 |
|  | 16-14 Ga. to 12-10 Ga. Step down butt connector | 21277 | 10 |

 **Moisture Resistant Nylon Insulated Butt Connectors**

Protect electrical connections from corrosive environments: road chemicals, salt spray, etc. Insert wire and crimp twice (electrical and mechanical) at each end. No need for heat or chemicals.

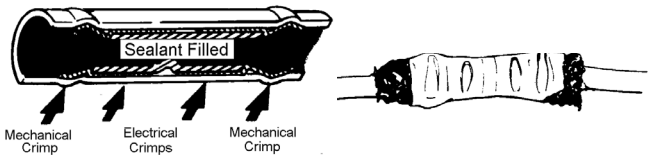

| Auveco Part No. | Wire Range | Color | Unit Pkg. |
|-----------------|------------|--------|-----------|
| 13683 | 22-18 Ga. | Red | 10 |
| 13684 | 16-14 Ga. | Blue | 10 |
| 13685 | 12-10 Ga. | Yellow | 10 |



Heat-Shrinkable, Solder-Type Closed-End Connector

Heat-shrinkable thermoplastic sleeve containing a spiral wound copper insert that is fitted with a pre-fluxed solder band. Easy installation: Insert stripped wires, then twist slightly. Twisting causes the copper insert to tightly grip, compress and hold the wires together. Apply heat.









Insulated & Sealed Closed-End Connector
Color Code: Green
Wire Range: 22-14 Gauge
Minimum Combination: 3 22 Gauge
Maximum Combination: 1 14 Gauge & 1 22 Gauge
UNIT PACKAGE: 10





Solderless Terminals
Non-Insulated
22-18 Gauge Wire Range

| Actual Size | Wire Size | Auveco Part No. | Unit Pkg. |
|---|----------------|-----------------|-----------|
|  | #4-#6 | 5000 | 100 |
|  | #8-#10 | 5002 | 100 |
|  | Butt Connector | 5044 | 100 |

16-14 Gauge Wire Range

| Actual Size | Wire Size | Auveco Part No. | Unit Pkg. |
|---|----------------|-----------------|-----------|
|  | #4-#6 | 5003 | 100 |
|  | #8-#10 | 5005 | 100 |
|  | #12-1/4" | 5006 | 100 |
|  | #4-#6 | 5014 | 100 |
|  | #8-#10 | 5015 | 100 |
|  | Butt Connector | 5045 | 100 |





16-14 Gauge Wire Range
High Temperature

| Actual Size | Wire Size | Auveco Part No. | Unit Pkg. |
|---|--------------|-----------------|-----------|
|  | #8-#10 | 17491 | 50 |
|  | #12-1/4" | 17492 | 50 |
|  | .187" Female | 10724 | 25 |
|  | 1/4" Female | 5066 | 100 |
|  | 1/4" Male | 17490 | 50 |



SOLDERLESS TERMINALS

Non-Insulated

12-10 Gauge Wire Range

| Actual Size | Wire Size | Auveco Part No. | Unit Pkg. |
|---|----------------|-----------------|-----------|
|  | #8-#10 | 5007 | 100 |
|  | #12-1/4" | 5008 | 100 |
|  | 5/16" | 5009 | 100 |
|  | 3/8" | 5010 | 100 |
|  | Butt Connector | 5046 | 100 |

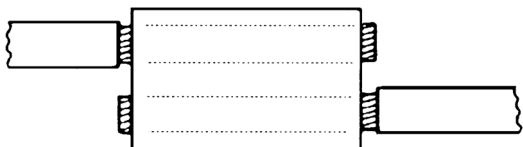

Parallel Connectors (Fusible Link Connectors)

| Actual Size | Wire Size | Auveco Part No. | Unit Pkg. |
|---|-----------|-----------------|-----------|
|  | 16-14 Ga. | 12630 | 100 |
|  | 12-10 Ga. | 12631 | 50 |





Parallel Connectors Proper Wire Insertion



Splice Clips

| Actual Size | Wire Size | Auveco Part No. | Unit Pkg. |
|---|-------------------|-----------------|-----------|
|  | Max. of 3 #16 Ga. | 18952 | 50 |
|  | Max of 3 #12 Ga. | 22341 | 25 |





8 Gauge Wire Range

| Actual Size | Wire Size | Auveco Part No. | Unit Pkg. |
|---|-----------|-----------------|-----------|
|  | 1/4" | 15158 | 25 |
|  | 5/16" | 15159 | 25 |



8 Gauge Wire Range

| Actual Size | Wire Size | Auveco Part No. | Unit Pkg. |
|--|-----------|-----------------|-----------|
|  | 3/8" | 15160 | 25 |
|  | 1/2" | 15161 | 25 |

6 Gauge Wire Range

| Actual Size | Wire Size | Auveco Part No. | Unit Pkg. |
|--|-----------|-----------------|-----------|
|  | 1/4" | 15162 | 25 |
|  | 5/16" | 15163 | 25 |
|  | 3/8" | 15164 | 25 |
|  | 1/2" | 15165 | 25 |

4 Gauge Wire Range

| Actual Size | Wire Size | Auveco Part No. | Unit Pkg. |
|--|-----------|-----------------|-----------|
|  | 1/4" | 15166 | 10 |
|  | 5/16" | 15167 | 10 |
|  | 3/8" | 15168 | 10 |

Tap Splice Electrical Connectors

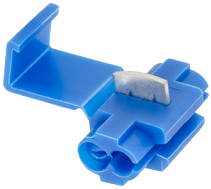

Make quick, reliable pre-insulated tap splices, in-line splices, pass-through connections and pigtail connections without stripping, twisting, soldering or using special tools.

Easy to use:

- Open the connector making sure the piercing barb is clear of the wire channels.
- Insert unstripped wires in the proper channels.
- Use pliers to squeeze down the piercing barb until the top is flush with the connector body.
- Close the hinged cover so it locks securely.

| Auveco Part No. | Wire Size | Color | Unit Pkg. |
|-----------------|-----------|-------|-----------|
| 17036 | 22-18 Ga. | Red | 25 |
| 9481 | 18-14 Ga. | Blue | 25 |
| 14896 | 18-14 Ga. | Blue | 100 |
| 14897 | 18-14 Ga. | Blue | 500 |



10385
Tan

Heavy duty self-stripping connector designed for 14, 16, 18 gauge wire connected on to 10 or 12 gauge automotive wire. Ideal for over the road equipment where tap, in-line, and pigtail splices are required.

UNIT PACKAGE: 10



10386
Yellow

Designed exclusively for 10 or 12 gauge splicing on heavy duty vehicle wiring. Tap, in-line, and pigtail splices made quick and easy with this self-stripping connector.

UNIT PACKAGE: 10



10319

Bullet receptacle connector for use with 18-14 gauge wire. Mates with Auveco snap plugs 5063 and 12146. Place wire to be tapped into connector channel, snap body together and lock into place with pliers.

UNIT PACKAGE: 10

Moisture-Resistant Tap Connector

Tap connector with patented application system forces protective gel around the wire and element, providing a moisture-resistant barrier to destructive substances such as salt water and other corrosive environments. Withstands continuous operating temperatures of -40°C to 75°C (-40°F to 167°F).

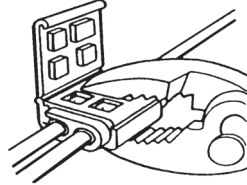

| Auveco Part No. | Wire Size | Color | Unit Pkg. |
|-----------------|-----------|-------|-----------|
| 17360 | 18-14 Ga. | Blue | 50 |

Electrical Connectors



Fully insulated connector for tapping into a line without stripping the insulation. No special tools are required.

Place wire to be tapped in locating notch. Then close with pliers.

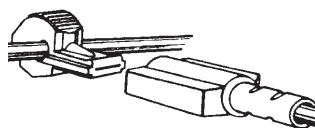
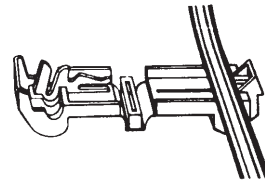

Make connection with Auveco insulated male terminal: 11828 (22-18 Gauge), 11605 (16-14 Gauge) or 11830 (12 Gauge)

| Auveco Part No. | Wire Size | Color | Unit Pkg. |
|-----------------|-----------|--------|-----------|
| 12791 | 22-18 Ga. | Red | 10 |
| 12161 | 18-14 Ga. | Blue | 10 |
| 14898 | 18-14 Ga. | Blue | 100 |
| 12792 | 12 Ga. | Yellow | 10 |



14920
With Sealant

Self-stripping connector for making 2 or 3 wire pigtail connections with a wire range of 22-14 gauge.

Simply insert 2 or 3 unstripped wires completely into the connector. Hold a crimping tool perpendicular to the wires and make the connection by driving the cap down. For use to 600V maximum.

UNIT PACKAGE: 10

O.E.M. SHELLS

GM Weather Pack Series • *Photos not actual size*

Sec. 12



15949
(12010996)
Nylon

Single Cavity Shroud
Mates with Auveco 15950

UNIT PACKAGE: 25



15953
(12010717)
Nylon

Triple Cavity Shroud
Mates with Auveco 15954

UNIT PACKAGE: 15



18147
(12015798)
Nylon

4 Cavity Square Tower
Mates with Auveco 18148

UNIT PACKAGE: 5



15950
(12015791)
Nylon

Single Cavity Tower
Mates with Auveco 15949

UNIT PACKAGE: 25



15954
(12015793)
Nylon

Triple Cavity Tower
Mates with Auveco 15953

UNIT PACKAGE: 15



18148
(12015024)
Nylon

4 Cavity Square Shroud
Mates with Auveco 18147

UNIT PACKAGE: 5



15951
(12010973)
Nylon

Double Cavity Shroud
Mates with Auveco 15952

UNIT PACKAGE: 25



18145
(12015797)
Nylon

4 Cavity Flat Tower
Mates with Auveco 18146

UNIT PACKAGE: 5



18149
(12034342)
Nylon

5 Cavity Round Tower
Mates with Auveco 18150

UNIT PACKAGE: 2

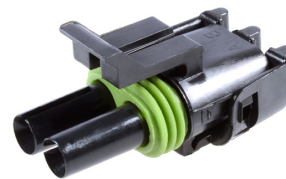

15952
(12015792)
Nylon

Double Cavity Tower
Mates with Auveco 15951

UNIT PACKAGE: 25



18146
(12010974)
Nylon

4 Cavity
Flat Shroud
Mates with Auveco 18145

UNIT PACKAGE: 5



18150
(12065158)
Nylon

5 Cavity
Round Shroud
Mates with Auveco 18149

UNIT PACKAGE: 5



18151
(12015799)
Nylon

6 Cavity Flat Tower
Mates with Auveco 18152

UNIT PACKAGE: 3

O.E.M. SHELLS

GM Weather Pack Series • *Photos not actual size*



18152

(12010975)

Nylon

6 Cavity Flat Shroud
Mates with Auveco 18151

UNIT PACKAGE: 5



14462

(12014012)

Weather Pack Terminal Extractor Tool
Designed for extracting Weather Pack terminals from their connector housing. Slide the hollow shaft of the tool over the retention barbs of the terminal. Then pull the terminal out of its shell.

UNIT PACKAGE: 1

O.E.M. TERMINALS

GM Weather Pack Series

Male Terminals are used with Shrouds • Female Terminals are used with Towers

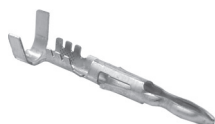

20747

(GM: 12089307)

Tin Plated

Gauge: 24-22
Mates with Auveco 20748

UNIT PACKAGE: 15



15937

(12010182, 12124580)

Tin Plated

Gauge: 16-14
Mates with Auveco 15948

UNIT PACKAGE: 50



20748

(GM: 12020801)

Tin Plated

Gauge: 24-22
Mates with Auveco 20747

UNIT PACKAGE: 15

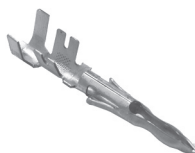

18325

(12089306, 12124587)

Tin Plated

Gauge: 12
20 Amp Max.
Mates with Auveco 18324

UNIT PACKAGE: 25



14151

(12034051, 12089188)

Tin Plated

Gauge: 20-18
Mates with Auveco 14150

UNIT PACKAGE: 50



18324

(12015917, 12124581)

Tin Plated

Gauge: 12
20 Amp Max.
Mates with Auveco 18325

UNIT PACKAGE: 25



14150

(12033674, 12089040)

Tin Plated

Gauge: 20-18
Mates with Auveco 14151

UNIT PACKAGE: 50



20749

(GM: 12015899)

Red Silicone

Cable Seal
Use with Auveco 20747 & 20748

UNIT PACKAGE: 25

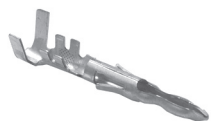

15948

(12010085, 12089305)

Tin Plated

Gauge: 16-14
Mates with Auveco 15937

UNIT PACKAGE: 50



14152

(12015323)

Green Silicone

Cable seal
Use with Auveco 14150, 14151, 15937 & 15948

UNIT PACKAGE: 50

O.E.M. TERMINALS

GM Weather Pack Series

Sec. 12

Male Terminals are used with Shrouds • Female Terminals are used with Towers



18326

(12010293)
Gray Silicone

Use with 14 Gauge GPT & Cross-Link
Polyethylene Primary Wire

UNIT PACKAGE: 25



14154

(12014837)

Gauge: 20-18
Set of 14151 and 14152

UNIT PACKAGE: 25 Sets



20618

(12015193)
Blue Silicone

Use with Auveco 18324 & 18325

UNIT PACKAGE: 25



15955

(12010300)
Silicone

Cavity Plug
Used to plug empty cavities in connector shell

UNIT PACKAGE: 25



14153

(12014836)

Gauge: 20-18
Set of 14150 & 14152

UNIT PACKAGE: 25 Sets



15921

Repair Lead Gauge: 20-18
Gauge Wire: 10" of 18

UNIT PACKAGE: 5



15922

Repair Lead Gauge: 20-18
Gauge Wire: 10" of 18

UNIT PACKAGE: 5

O.E.M. TERMINALS



15957

(2965142)
Tin Plated

Gauge: 16-14
Insulated with shell 8777
Mates with terminal 15956

UNIT PACKAGE: 25



8776

(2962987)
Tin Plated

Gauge: 16-14
Insulated with shell 8775
Mates with terminal 8774

UNIT PACKAGE: 50



15956

(2971962)
Tin Plated

Gauge: 16-14
Insulated with shell 8775
Mates with terminal 15957

UNIT PACKAGE: 25



17002

(8917283;12015878)
Tin Plated
Copper

Gauge: 12-10
Insulated with shell 8775

UNIT PACKAGE: 25



8774

(2084421,2962447)
Unplated Brass

Gauge: 16-14
Insulated with shell 8777
Mates with terminal 8776

UNIT PACKAGE: 50



8775

(2962984)

Insulates 8776 and 15956
Mates with shell 8777

UNIT PACKAGE: 25



8777

(2962448)

Insulates 8774 and 15957
Mates with shell 8775

UNIT PACKAGE: 25

GM Micro - Pack Terminals



14883

(12020757)
Tin Plated

Gauge: 20-18

UNIT PACKAGE: 10



15924

(12040902)
Tin Plated

Gauge: 22

UNIT PACKAGE: 50

GM Pack-Con I Series Terminals



11948

(8900524, 12020320)
Tin Plated

Gauge: 16-14
Mates with Auveco 15935

UNIT PACKAGE: 25



15935

(12020347)

Gauge: 16-14
Mates with Auveco 11948

UNIT PACKAGE: 50

GM Pack-Con H.D. I Series Terminals



15960

(12033817)
Tin Plated

Gauge: 12-10

UNIT PACKAGE: 25

GM Pack-Con III Series Terminals



18650

(12020321)
Brass

Gauge: 16-14

UNIT PACKAGE: 25

GM Metri-Pack 150 Series Terminals



18653

(12045773)
Tin Plated

Gauge: 20-18

UNIT PACKAGE: 25



15498

(12047581)
Tin Plated

Gauge: 20-18
Mates with Auveco 15497

UNIT PACKAGE: 25



15497

(12047680)
Tin Plated

Gauge: 20-18
Mates with Auveco 15498

UNIT PACKAGE: 25



18654

(12048074)
Tin Plated

Gauge: 20-18

UNIT PACKAGE: 25



15499

(GM: 12047767; Chry: 4368618)
Tin Plated

Gauge: 20-16

UNIT PACKAGE: 25



20212

(12129484)
Tin Plated

Gauge: 18-16

UNIT PACKAGE: 15



20213

(12129373)
Tin Plated

Gauge: 22-20

UNIT PACKAGE: 15

GM Metri-Pack 150.2 Pull to Seat



20214

(12124075)
Tin Plated

Gauge: 18-16

UNIT PACKAGE: 15



20215

(12124076)
Tin Plated

Gauge: 22-20

UNIT PACKAGE: 15

GM Metri-Pack 150.1 Series Terminal



16806

(12052922, 12089340)

Gauge: 20-18

Not for use with 150.2 Series

UNIT PACKAGE: 25

GM 56 Series Terminal



18690

(2973215)
Tin Plated

Two Gauge Leads: 16-14

Or One Gauge Lead: 12

Fits 5/16" Male Tab

UNIT PACKAGE: 25

GM 59 Series Terminal



18651

(2973216)
Tin Plated

Gauge: 16-14

Blade Size: 5/16"

UNIT PACKAGE: 25

GM Metri-Pack 280 Series Terminal



18659

(12129497)
Tin Plated

Gauge: 16-14

Mates with Auveco 18658

UNIT PACKAGE: 25



14880

(12020116)
Tin Plated

Gauge: 16-14

Mates with Auveco 14881

UNIT PACKAGE: 25

GM Metri-Pack 280 Series Terminal



15946

(12034047)
Tin Plated

Gauge: 20-18

Mates with Auveco 15947

UNIT PACKAGE: 50



18658

(12129493)
Tin Plated

Gauge: 16-14

Mates with Auveco 18659

UNIT PACKAGE: 25



14881

(12015857)
Tin Plated

Gauge: 16-14

Mates with Auveco 14880

UNIT PACKAGE: 25



15947

(12034046)
Tin Plated

Gauge: 20-18

Mates with Auveco 15946

UNIT PACKAGE: 50



20216

(12015858)
Tin Plated

Gauge: 12-10

UNIT PACKAGE: 15



20220

(12186456)
Tin Plated

Gauge: 14-12

Mates with Auveco 20226

UNIT PACKAGE: 15



20226

(12092344)
Tin Plated

Gauge: 14-12

Mates with Auveco 20220

UNIT PACKAGE: 15

GM Metri-Pack 280 Series Terminal



20221
(12186457)
Tin Plated

Gauge: 18-16
Mates with Auveco 20227

UNIT PACKAGE: 15



20227
(12092345)
Tin Plated

Gauge: 18-16
Mates with Auveco 20221

UNIT PACKAGE: 15

GM Metri-Pack 280 Series Tangless



20217
(12110842)
Tin Plated

Gauge: 14-12
Used without cable seal

UNIT PACKAGE: 15



20222
(12110845)
Tin Plated

Gauge: 14-12
Used with cable seal

UNIT PACKAGE: 15



20223
(12129409)
Tin Plated

Gauge: 16-14
Used with cable seal

UNIT PACKAGE: 15



20218
(12110844)
Tin Plated

Gauge: 18-16
Used without cable seal

UNIT PACKAGE: 15



20224
(12110847)
Tin Plated

Gauge: 18-16
Used with cable seal

UNIT PACKAGE: 15

GM Metri-Pack 280 Series Tangless



20219
(12110843)
Tin Plated

Gauge: 22-20
Used without Cable seal

UNIT PACKAGE: 15



20225
(12110846)
Tin Plated

Gauge: 22-20
Used with cable seal

UNIT PACKAGE: 15

GM Metri-Pack 280 Fuel Injector



20230
(12103360)
Tin Plated

Gauge: 22-20

UNIT PACKAGE: 15

GM Metri-Pack 480 Series



15939
(12020120)
Tin Plated

Gauge: 16-14
Blade Width: 3/16"
Mates with Auveco 15938

UNIT PACKAGE: 25



15938
(12015861)
Tin Plated

Gauge: 16-14
Mates with Auveco 15939

UNIT PACKAGE: 25

GM Metri-Pack 630 Series



15944
(12020126)
Tin Plated

Gauge: 16-14
Blade Width: 1/4"
Mates with Auveco 15945

UNIT PACKAGE: 50

GM Metri-Pack 630 Series



15945
(12015870)
Tin Plated

Gauge: 16-14
Mates with Auveco 15944

UNIT PACKAGE: 50

GM Metri-Pack 630 Pull to Seat



20231
(12066614)
Tin Plated

Gauge: 16-14

UNIT PACKAGE: 15

GM Micro-Pack 100 W Series Terminals



20209
(12084912)
Gold/Nickel Plated

Gauge: 18
Mates with Auveco 20211

UNIT PACKAGE: 10



20211
(12160551)
Gold/Nickel Plated

Gauge: 18
Mates with Auveco 20209

UNIT PACKAGE: 10



20210
(12084913)
Gold/Nickel Plated

Gauge: 22-20

UNIT PACKAGE: 10

Ford Wedglock Pin Type Terminals



20475
(E7EB-14461-BA)
Tin Plated

Gauge: 20-18
Diameter Pin: .060"

UNIT PACKAGE: 25

Ford Wedglock Pin Type Terminals



14887
(D1AB-14461-AA)

Gauge: 20-18
Diameter Pin: .110"
Mates with Auveco 14888

UNIT PACKAGE: 25



14888
(D1AB-14488-CA)

Gauge: 20-18
Diameter Pin: .110"
Mates with Auveco 14887

UNIT PACKAGE: 25

Ford Miniature Pin Type Terminals



18853
(E3VB-14461-AA)

Gauge: 20-18
Diameter Pin: .062"
Reference A-9

UNIT PACKAGE: 25

Ford Mini Block Terminals



16342
(E7EB-14421-EA)

Gauge: 20-18
Blade Width: 1/8"
Mates with Auveco 16344

UNIT PACKAGE: 25



16344
(E7EB-14474-CA)

Gauge: 20-18
For 1/8" Blade
Mates with Auveco 16342

UNIT PACKAGE: 25

Ford Standard Box Terminals



16348
(E8EB-14474-VA)
Tin Plated

Gauge: 16-14
For 3/16" Blade

UNIT PACKAGE: 25



14889
(D8BB-14474-BA, D3AB-14474-DA)

Gauge: 20-18

UNIT PACKAGE: 25

Ford Terminals



20815
(D20B-14421-BB)

Gauge: 20-18
Blade Width: 3/16"
Replaces Auveco 14890

UNIT PACKAGE: 25



20816
(D5AB-14474-FA, D3AZ-14474-G)

Gauge: 20-18
Replaces Auveco 14891

UNIT PACKAGE: 25

Chrysler Quick Connect Terminals



16349
(3843386)

Gauge: 16-14
Blade Width: 1/4"

UNIT PACKAGE: 25

Chrysler Terminals



16801
(7368261)

Gauge: 20-18
Diameter Pin: 3/32"
Male

UNIT PACKAGE: 25



16804
(4304729)

Gauge: 24-18
Double Cantilever Spring Terminal
Used with P.C. board connections & general purpose

UNIT PACKAGE: 25

UNIVERSAL TERMINALS



14892
(GM: 2965470;
Ford: C5AB-14474-B;
Chry: 2096466)
Unplated Brass

Gauge: 20-18
Female: 1/4"

UNIT PACKAGE: 25



17115
(GM: 2962953;
Ford: C2TB-14462A;
Chry: 2096454)
Bare Copper

Gauge: 12-10
Stud Size: 3/8" (10mm)

UNIT PACKAGE: 25



15504
(GM: 2965580;
Ford: C1SF-14474-A;
Chry: 2096467)
Unplated Brass

Gauge: 14-12
Female: 1/4"

UNIT PACKAGE: 25



21401
(GM: 2984172;
Ford: C8AB-14463N;
Chry: 4274166)
Tin Plated

Gauge: 16-14
Stud Size: 1/4" (6.3mm)
Locking Type

UNIT PACKAGE: 10

MATE-N-LOCK TERMINALS

Commonly used in cellular phone and communication equipment installations, office machines and machine controls.



18855

Tin Plated Brass

Gauge: 20-14
Diameter Pin: .084"
Single Retention Barb
Mates with Auveco 18856

UNIT PACKAGE: 25



18856

Tin Plated Brass

Gauge: 20-14
Diameter Pin: .084"
Single Retention Barb
Mates with Auveco 18855

UNIT PACKAGE: 25



18857

Tin Plated Brass

Gauge: 20-14
Diameter Pin: .084"
Dual Retention Barbs
Mates with Auveco 18858

UNIT PACKAGE: 25



18858

Tin Plated Brass

Gauge: 20-14
Diameter Pin: .084"
Dual Retention Barbs
Mates with Auveco 18857

UNIT PACKAGE: 25

Terminal Extractor Picks



Photo not actual size

Used to release most GM, Ford and Chrysler OEM terminals from their insulating shells. Not suitable for round, pin-type terminals.

14884

(12012000)

Narrow Blade (.050")

UNIT PACKAGE: 1

14885

(8913369)

Wide Blade (.090")

UNIT PACKAGE: 1

20583

(12094429)

Micro Terminal Extractor Pick

.035" Wide Blade used to release: 150 Metri-Pack, 280 Metri-Pack, 280 Tangless, 280 Bus Bar, 630 Pull to Seat, GT 150, GT 280, Wedge Base Light Socket terminals and indexing Candelabra Bayonet Double Contact Light Socket terminals.

UNIT PACKAGE: 1

CRIMPING & CUTTING TOOLS

20901

Electrical Connector Separator

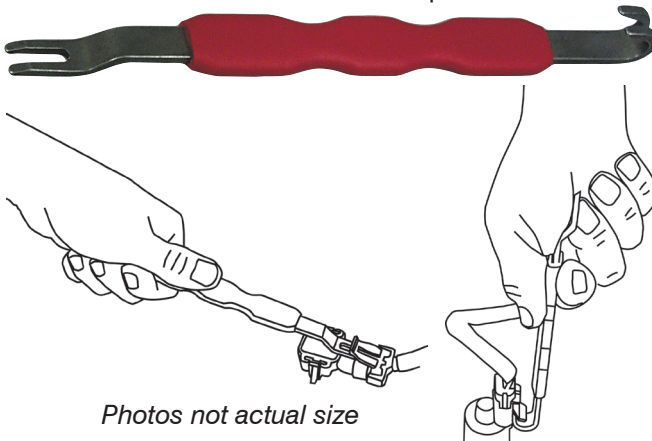

Photos not actual size

Quickly disconnects electrical connectors without damage. Simply engage the tool tip behind the connector locking clip and then pull or push to disconnect. The tool is double-ended to fit different access angles. Works on Weather Pack and other automotive electrical connectors.

UNIT PACKAGE: 1

15035

Self-Adjusting Wire Stripper/Crimping Tool



Photos not actual size

The quick and easy way to strip wire. Unique steel jaws self-adjust to strip any 26 - 10 gauge wire. Only light handle pressure is needed to make wire stripping fast and easy.

Crimps insulated and non-insulated 22 - 10 gauge and 7mm/8mm terminals

Also features precision machined blade for cutting wire sharp and smooth.

Overall Length: 8-1/4"

UNIT PACKAGE: 1

Photos not actual size

21424

Wire Stripper for recessed areas



This specially designed, narrow profile tool provides easy access to limited and hard-to-reach areas.

Strips 22-12 gauge single or multiple-stranded conductor wire and automatically adjusts to the wire size. The tool has an adjustable strip length gauge and built in wire cutter.
Lightweight and easy to use

UNIT PACKAGE: 1

Open Barrel Terminal Crimping Tool For O.E.M. Terminals



16004

Duplicates factory crimps on open barrel terminals used in automotive, computer and control applications. Features five machined and hardened crimp stations for 14 to 24 gauge wire terminations. Parallel jaws eliminate faulty crimps.
Overall Length: 8-1/2"

UNIT PACKAGE: 1

Insulation Crimp:

Crimp Station A for 14-18 Gauge
Crimp Station B for 20-24 Gauge

Stripped Wire Crimp:

Crimp Station C for 14-16 Gauge
Crimp Station D for 18-20 Gauge
Crimp Station E for 22-24 Gauge

7711

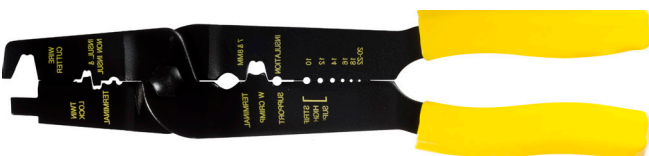

Cuts and strips 22-8 gauge wire. Crimps insulated and non-insulated solderless terminals in sizes from 22-10 gauge.
Overall Length: 9"

UNIT PACKAGE: 1

20751

(GM: 12014254)



Weather Pack Crimping Tool designed specifically to crimp only Weather Pack 20-18 Gauge & 16-14 Gauge Weather Pack seals and terminals in one cycle. Ratchet mechanism ensures completion of cycle.

UNIT PACKAGE: 1

20750

Micro Crimper
30-16 Gauge
Best for 24-20 Gauge

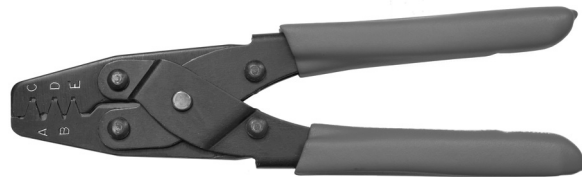

Insulation Crimp:

Crimp Station A for 20-16 Gauge
Crimp Station B for 30-22 Gauge

Stripped Wire Crimp:

Use Crimp Station C for 18-16 Gauge
Use Crimp Station D for 22-20 Gauge
Use Crimp Station E for 30-24 Gauge

UNIT PACKAGE: 1

20752

(GM: 12085270)

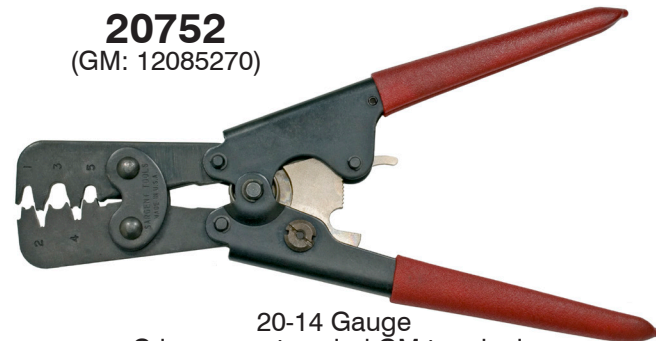

20-14 Gauge
Crimps most sealed GM terminals
Ratchet mechanism ensures completion of crimp cycle

Seal Crimp:

Crimp Station 1 for 150 Series Metri-Pack Seals
Crimp Station 3 for 480 & 630 Series Metri-Pack Seals
Crimp Station 5 for Weather Pack & 280 Series Metri-Pack Seals

Stripped Wire Crimp:

Crimp Station 2 for 20-18 Gauge
Crimp Station 4 for 16-14 Gauge

UNIT PACKAGE: 1

Twist-Type Wire Connectors



Color: Gray

Joins 18 & 16 Gauge Wires
Minimum of 2 #18 Gauge Wires
Maximum of 2 #16 Gauge Wires

10378: UNIT PACKAGE: 25
15204: UNIT PACKAGE: 100



Color: Blue

Joins 18-14 Gauge Wires
Minimum of 2 #18 Gauge Wires
Maximum of 3 #16 Gauge Wires

10379: UNIT PACKAGE: 25
15205: UNIT PACKAGE: 100



Color: Orange

Joins 18-14 Gauge Wires
Minimum of 2 #18 Gauge Wires
Maximum of 3 #16 Ga &
1 #18 Gauge Wires

10380: UNIT PACKAGE: 25
15206: UNIT PACKAGE: 100



Color: Yellow

Joins 18-12 Gauge Wires
Minimum of 1 #14 Gauge &
1 #18 Gauge Wires
Maximum of 2 #14 Gauge &
3 #16 Gauge Wires

10381: UNIT PACKAGE: 25
15207: UNIT PACKAGE: 100



Color: Red

Joins 18-10 Gauge Wires
Minimum of 1 #12 Gauge &
2 #18 Gauge Wires
Maximum of 2 #10 Gauge &
1 #12 Gauge Wires

10382: UNIT PACKAGE: 25
15208: UNIT PACKAGE: 100

Twist-Type Wire Connectors

Combines both the wide range and torque of wing-style connectors with a new flexible skirt that provides over-strip protection without taking additional space in the electrical box.



18312

Orange & Blue

Joins from two 22 gauge
to two 12 gauge wires

UNIT PACKAGE: 25

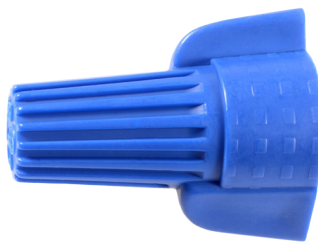

Wing Twist-Type Wire Connectors

Color: Blue

Joins 14-6 Ga. Wires
Minimum of 1 #10 Ga. & 1
#12 Ga. Wires
Maximum of 1 #6 Ga. & 2
#8 Ga.

10384 UNIT PACKAGE: 25
15209 UNIT PACKAGE: 50



15705

Yellow

Joins 22-12 Ga. Wires
Minimum of 2 #18 Ga. Wires
Maximum of 2 #12 Ga. Wires

UNIT PACKAGE: 50



15706

Red

Joins 20-8 Ga. Wires
Minimum of 2 #16 Ga. Wires
Maximum of 4 #12 Ga. Wires

UNIT PACKAGE: 50

CIRCUIT TESTER

20818

Photo not actual size



Computer Safe Automotive Logic Probe

This circuit tester with its high impedance feature draws less than 7 milliamps to protect all vehicle circuits including computerized engine and body controls, sensitive electronic sensors, microprocessors, electronic ignition components and air bags. Instructions included.

For 6, 12 and 24 volt systems

Insulated probe has an exposed length of 3-3/8"
Includes Protect-A-Terminal® Probe Adapter to prevent damage to electrical connectors
6 feet of heavy duty, 18 gauge dual leads with large battery clips for easy hook-up.

UNIT PACKAGE: 1

20819

Photo not actual size



Heavy Duty Circuit Tester

An excellent quality electrical circuit tester for checking 6 and 12 volt systems. It's made to last! Has a heavy duty battery clip. 5 feet of tough, flexible, heavily insulated rubber coated wire is retained in a spring supported strain-relief design that withstands the most rugged use.

UNIT PACKAGE: 1

**For Troubleshooting
DC Primary Circuits
on 6 & 12 Volt
Vehicles**



Photo not actual size

16420

Use to Check:
Lighting Systems
Wipers
Horn
Electric Clock,
Windows, Locks
Fuses
Relays

Features:

- 4 Feet of Wire
- Mechanical Strain Relief
- Impact & Chemical Resistant Housing
- 8" Long Probe/Housing
- Super Sharp Probe, Tempered to Last
- 2" Long Alligator Clip

UNIT PACKAGE: 1

WIRE LOOM

Split Flexible Tubing • Maximum Temperature of 345°F



I.D. 1/4" - O.D. 3/8"
Nylon 6 - Black

14197: 10' Length
14201: 50' Length (Bulk)



I.D. 3/8" - O.D. 9/16"
Nylon 6 - Black

14198: 10' Length
14202: 50' Length (Bulk)



I.D. 1/2" - O.D. 11/16"
Nylon 6 - Black

14199: 10' Length
14203: 50' Length (Bulk)



I.D. 5/8"
O.D. 13/16"
Nylon 6
Black

20536:
50' Length

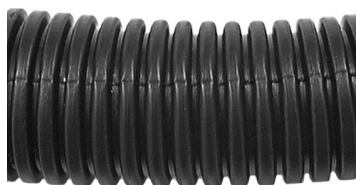

I.D. 3/4" - O.D. 15/16"
Nylon 6 - Black

14200:
10' Length
14204:
50' Length (Bulk)



I.D. 1"
O.D. 1-1/8"
Nylon 6
Black

18194:
25' Length

**Please place orders in
Unit Package quantities,
not based on pieces needed**

PRIMARY AND FUSIBLE WIRE

Photos not actual size



Primary Wire

Standard PVC Insulation (SE/GPT Type)
Suitable for most automotive applications.
Free of stripping, abrasion resistant,
meets most O.E.M. vehicle standards

UNIT PACKAGE: 1 Roll

The lower the gauge number, the thicker the wire
(i.e. 10 gauge is thicker than 16 gauge)

| Gauge | Stranding | Outer Diameter | Auveco Part No. | | | | Length |
|-------|-----------|----------------|-----------------|--------------|--------------|--------------|--------|
| | | | Red | White | Black | Blue | |
| 18 | 16 x 30 | .092 | 20486 | 20487 | 20488 | 20489 | 45 Ft. |
| 16 | 19 x 29 | .104 | 20490 | 20491 | 20492 | 20493 | 35 Ft. |
| 12 | 19 x 25 | .142 | 20494 | 20495 | 20496 | 20497 | 15 Ft. |
| 10 | 19 x 23 | .175 | 20498 | 20499 | 20500 | 20501 | 10 Ft. |

25 Foot Spool

| Gauge | Stranding | Outer Diameter | Auveco Part No. | | | | | Yellow |
|-------|-----------|----------------|-----------------|--------------|--------------|--------------|--------------|--------------|
| | | | Red | White | Black | Blue | Green | |
| 14 | 19 x 27 | .117 | 12419 | 12420 | 12421 | 12422 | 15239 | 15240 |

100 Foot Spool

| Gauge | Stranding | Outer Diameter | Auveco Part No. | | | | | | |
|-------|-----------|----------------|-----------------|--------------|--------------|--------------|--------------|--------------|--------------|
| | | | Red | White | Black | Blue | Green | Yellow | Brown |
| 20 | 10 x 30 | .085 | 21339 | 21340 | 21341 | 21342 | 21343 | 21344 | 21345 |
| 18 | 16 x 30 | .092 | 12423 | 12424 | 12425 | 12426 | 12427 | 12428 | 15256 |
| 16 | 19 x 29 | .104 | 12429 | 12430 | 12431 | 12432 | 12433 | 12434 | 15257 |
| 14 | 19 x 27 | .117 | 12435 | 12436 | 12437 | | 12439 | 12440 | 15258 |
| 12 | 19 x 25 | .142 | 12441 | 12442 | 12443 | 12444 | 15259 | 15260 | |
| 10 | 19 x 23 | .175 | 12445 | | 12447 | 12448 | | 15263 | |

Spooled Fusible Link Wire

The lower the gauge number, the thicker the wire (i.e. 10 Ga. is thicker than 16 Ga.)



A fusible link is a special section of low tension cable installed by an OEM and designed to open a circuit when subjected to extreme current overload. Its purpose is to minimize wiring system damage when such an overload accidentally occurs in those circuits protected by the fusible link. A short circuit causes the fusible link to act as an element in a "slow-blow" fuse. A fusible link is not intended to be used in place of a fuse but only where a fuse cannot be economically employed. Our fusible line wire meets the requirements of SE J-156 and the insulation has the characteristics as listed for EAE, SE J-1128 Type SXL. The vehicle manufacturer should be consulted about questions on fusible link length and size. General practice has been for a fusible link to be 4 gauges smaller than the circuit wire.

Example: if the circuit wire is 12 gauge, use a 16 gauge fusible link.

Final determination should be based on O.E.M. application.

Note: Extreme care should be taken to always replace a fusible link with then same gauge and length as installed by the manufacturer.

| Auveco Part No. | Gauge | Color | Length | Replaces | Unit Pkg. |
|-----------------|-------|---------------|--------|-------------|-----------|
| 15372 | 14 | Orange | 25 Ft. | GM: 6292995 | 1 Spool |
| 20484 | 8 | Black or Rust | 25 Ft. | | 1 Spool |

*Color may vary at manufacturer's option

FUSIBLE LINKS

Photos not actual size



Universal Fusible Links

| Auveco Part No. | Gauge | Length | Replaces | Unit Pkg. |
|-----------------|-------|--------|--|-----------|
| 12627 | 18 | 9" | Chry: 3843392 & other 18 Ga. links | 5 |
| 12628 | 16 | 9" | GM: 6292996, 8903489 Ford D3AZ-14526-E & other 16 Ga. links | 5 |
| 12629 | 14 | 9" | GM: 6292995, 8903488 Ford D3AZ-14526D & other 14 Ga. links | 5 |
| 17465 | 12 | 9" | GM: 6293923 | 5 |
| 17464 | 10 | 9" | GM: 12077140 | 5 |

TEST CLIPS



Type 1

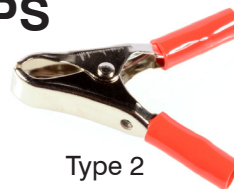

Type 2

| Auveco Part No. | Type | Description | Unit Pkg. |
|-----------------|------|--|-----------|
| 20478 | 1 | 10 Amp, Alligator Clip, Nickel Plated, 2" Long | 5 |
| 16969 | 2 | 10 Amp, Red Insulation, 2-1/4" Long | 5 |
| 16970 | 2 | 10 Amp, Black Insulation, 2-1/4" Long | 5 |
| 16971 | 2 | 1 Each of 16969 & 16970 | 1 Pair |
| 16972 | 2 | 30 Amp, Red Insulation, 3" Long | 5 |
| 16973 | 2 | 30 Amp, Black Insulation, 3" Long | 5 |
| 16974 | 2 | 1 Each of 16972 & 16973 | 1 Pair |
| 16975 | 2 | 50 Amp, Red Insulation, 3" Long | 5 |
| 16976 | 2 | 50 Amp, Black Insulation, 3" Long | 5 |
| 16977 | 2 | 1 Each of 16975 & 16976 | 1 Pair |

BATTERY CABLE & TERMINALS



Battery Cable

Bare Copper Standard Conductor, covered with tough black Polyvinyl Chloride insulation.

The thick jacket is easy to strip, resistant to moisture, weather, oil and acids.

| Auveco Part No. | Gauge | Stranding | O.D. | Unit Pkg. |
|-----------------|-------|-----------|------|-----------|
| 11392 | 4 | 70 x 22.5 | .380 | 25' Roll |
| 13850 | 1/0 | 133 x 21 | .530 | 25' Roll |
| 13851 | 2/0 | 133 x 20 | .590 | 25' Roll |

Solderless Battery Cable Terminals

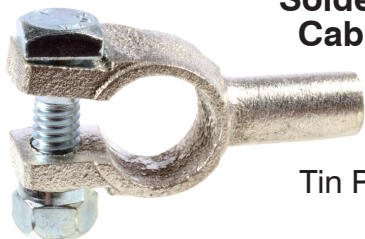

Tin Plated Copper

| Auveco Part No. | Cable Size | Post Size | Unit Pkg. |
|-----------------|-------------|-----------|-----------|
| 11360 | No. 6 AWG | Universal | 2 |
| 11361 | No. 4 AWG | Universal | 2 |
| 11362 | No. 1 AWG | Positive | 2 |
| 11363 | No. 1 AWG | Negative | 2 |
| 11364 | No. 1/0 AWG | Positive | 2 |
| 11365 | No. 1/0 AWG | Negative | 2 |
| 11366 | No. 2/0 AWG | Positive | 2 |
| 11367 | No. 2/0 AWG | Negative | 2 |
| 15858 | No. 3/0 AWG | Positive | 2 |

Note: Use with Auveco Tool No. 7996



Universal Battery Terminal

9948

For Positive & Negative Posts
Cable Range 8 thru 2/0 AWG

UNIT PACKAGE: 2

Marine Battery Terminals

Lead Plated Brass Terminal
Nickel Plated Grade 2 Steel Wing Nut
Zinc Plated Grade 2 Steel Bolt & Nut



8772

For Positive Posts
Stud: 3/8"-16

UNIT PACKAGE: 5



8773

For Negative Posts
Stud: 5/16"-18

UNIT PACKAGE: 5

BATTERY CABLE & TERMINALS

Photos not actual size

Sec. 12

Engine Ground & Bonding Strap



19499

Replacement for body to engine block straps. Solves light dimming problems by grounding charging system. Also reduces radio noise. Copper braided wire with tin-plated brass ring terminals.

Length: 8"
Gauge: 10
Stud Size Ring Terminal: 5/16" - 3/8"

UNIT PACKAGE: 2

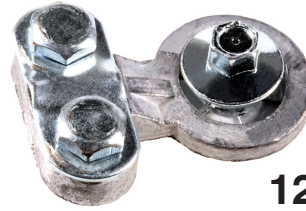

Universal Side Mount Battery Cable Terminal

12975

Fits all small diameter cables - both positive and negative.

UNIT PACKAGE: 2



All Lead Terminal

10808

Zinc Plated Steel Bolt & Nuts
Stud: 5/16"-18
Universal Positive & Negative

UNIT PACKAGE: 2

COMPRESSION BATTERY CABLE TERMINALS

All clamps and lugs are made of cast copper • All clamps, lugs and fasteners are tin plated

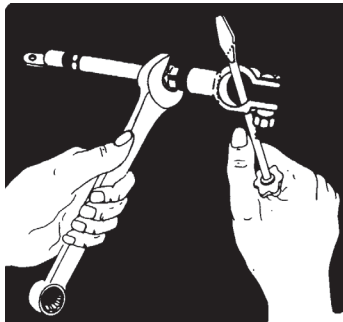

Assemble with common hand tools.

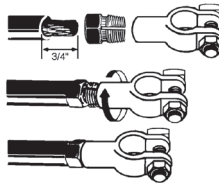

Three Easy Steps

- Strip 3/4" of insulation from the end of the cable. Insert bared wire into the compression nut.
- Thread terminal on compression nut.
- Grip compression nut with wrench and turn the terminal until the compression nut seats. With larger gauges you may want to hold the terminal in a vise



Straight Clamp

| Auveco Part No. | Cable Gauge | Description. | Color | Unit Pkg. |
|-----------------|-------------|--------------|--------|-----------|
| 15603 | 4 | Pos. | Gray | 2 |
| 15605 | 1&2 | Pos. | Green | 2 |
| 15606 | 1/0 | Neg. | Black | 2 |
| 15607 | 1/0 | Pos. | Black | 2 |
| 15608 | 2/0 | Neg. | Orange | 2 |
| 15609 | 2/0 | Pos. | Orange | 2 |
| 15610 | 3/0 | Neg. | Purple | 2 |
| 15611 | 3/0 | Pos. | Purple | 2 |



Heavy Wall Copper Lug

| Auveco Part No. | Cable Gauge | Hole Size | Color | Unit Pkg. |
|-----------------|-------------|-----------|--------|-----------|
| 15618 | 4 | 3/8" | Gray | 2 |
| 15619 | 1&2 | 3/8" | Green | 2 |
| 15620 | 1/0 | 3/8" | Black | 2 |
| 15621 | 1/0 | 1/2" | Black | 2 |
| 15622 | 2/0 | 3/8" | Orange | 2 |
| 15625 | 3/0 | 1/2" | Purple | 2 |



Stud/Side Terminal

| Auveco Part No. | Cable Gauge | Color | Unit Pkg. |
|-----------------|-------------|-------|-----------|
| 15628 | 1/0 | Black | 2 |



Compression Nut



| Auveco Part No. | Cable Gauge | Color | Unit Pkg. |
|-----------------|-------------|--------|-----------|
| 15632 | 2/0 | Orange | 5 |

Photos not actual size



Copper Battery Cable Lugs

| Auveco Part No. | Cable Size | Stud Size | Unit Pkg. |
|-----------------|------------|-----------|-----------|
| 5794 | 4 Ga. | 3/8" | 25 |
| 5796 | 1/0 Ga. | 3/8" | 25 |
| 11467 | 2/0 Ga. | 1/2" | 10 |

Use Auveco 7996 Crimping Tool

Heavy Duty Battery Cable Terminal Ends for Stud-Type Batteries
For Auto, Truck, Marine and H.D. Equipment



Single Barrel
Copper/Plated
Stud Size: 3/8

| Auveco Part No. | Cable Size | Unit Pkg. |
|-----------------|------------|-----------|
| 13810 | 1/0 | 2 |
| 13811 | 2/0 | 2 |

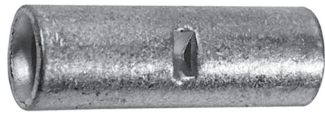

Butt Connector (Double Flared)

Pure Copper with Tin Plating

Applications: Field or shop splicing of battery cables and welding cables.

| Auveco Part No. | Cable Size | Length | Unit Pkg. |
|-----------------|------------|--------|-----------|
| 11729 | 2/0 Ga. | 1-3/4" | 5 |



Double Barrel
Copper/Plated
Stud Size: 3/8

| Auveco Part No. | Cable Size | Unit Pkg. |
|-----------------|------------|-----------|
| 13814 | 2/0 | 1 |



11083
(8917444)
Zinc

Battery Side Terminal Bolt
Thread Size: 3/8"-16
Overall Length: 1-1/8"
GM

UNIT PACKAGE: 10



19199
(12004188)
Zinc

Battery Side Terminal Bolt
Thread Size: 3/8"-16
Overall Length: 1-3/4"
GM

UNIT PACKAGE: 5



13816
Stainless Steel

Battery Hold Down Nuts
Thread Size: 3/8-16
Overall Length: 18/8

UNIT PACKAGE: 4

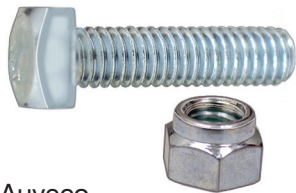

Battery Terminal Bolt & Nut
Zinc Chromate

| Auveco Part No. | Size | Unit Pkg. |
|-----------------|---------------------------------------|-----------|
| 3186 | 5/16"-18 x 1-1/4" Bolt w/Collared Nut | 100 |
| 8003 | 5/16"-18 x 1-1/4" Bolt W/Hex Nut | 50 |
| 14974 | 5/16"-18 x 1-1/4" Bolt Only | 50 |
| 14975 | 5/16"-18 Collared Nut Only | 50 |

Suggested Terminal Assemblies

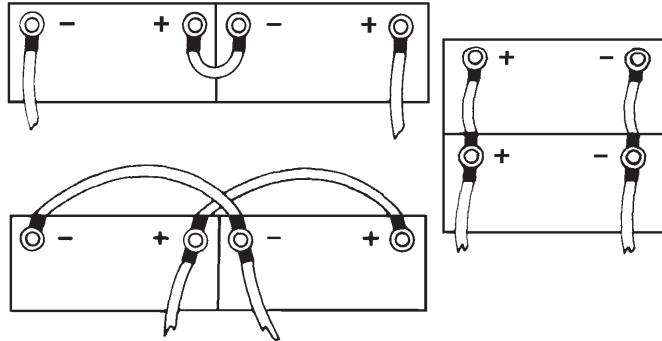

20899

Side Terminal Battery Cleaner

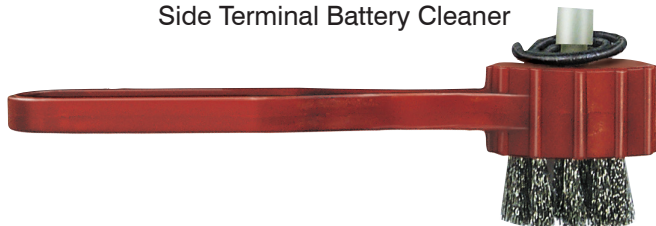

Coil spring cutters polish the battery contacts while the stainless steel brushes clean the cable terminals.

UNIT PACKAGE: 1

BATTERY TERMINAL TOOLS

Photos not actual size



20898
Battery Brush

Cleans dirt and corrosion from post type battery terminals and cable clamps. Made of heavy duty stainless steel wire. Case is made of high impact plastic that will not weaken in cleaning solutions.

UNIT PACKAGE: 1



15039
Anti-Corrosion Protectant

A non-drying coating protectant, formulated especially for battery terminals and other exposed electrical connections.

UNIT PACKAGE: 1 8oz. Can



7996

Crimps cable range
Gauge: 8 to 4/0
Use with vise or hammer

UNIT PACKAGE: 1

3M Vinyl Electrical Tape
Made in U.S.A.



.007" Thick x 3/4" Wide x 60 Ft. Long

16527: Unit Package: 5 Rolls
16578: Unit Package: 15 Rolls

General purpose vinyl insulating tape with excellent resistance to abrasion, moisture, alkalis, acid, copper corrosion and varying weather conditions. Can be used as a primary electrical insulation for all wire and cable splices rated up to 600 volts.

Linerless Self-Bonding Rubber Tape



14389

.030" Thick x 3/4" Wide x 15ft. Long

UNIT PACKAGE: 1 Roll

Replace heat shrink tubing with a safe, tight, long-lasting seal that withstands temperature extremes from -50° to 300°F. No heat guns or open flames needed. No paper liner to mess with.

Tape is stretched when applied and retains its elasticity to ensure a tight seal at all points. The tape is unaffected by salt spray and common automotive fluids. As long as it is stretched when it is applied, it will not unravel after application due to its self-bonding characteristics.

CIRCUIT BREAKERS

Automatic Re-Set

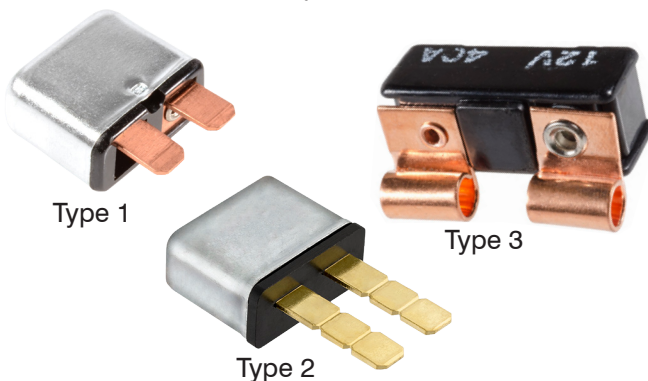

| Auveco Part No. | Type | Specifications | Unit Pkg. |
|-----------------|------|---------------------|-----------|
| 15046 | 1 | 30 Amps at 12 Volts | 5 |
| 18518 | 2 | 10 Amps at 12 Volts | 2 |
| 18519 | 2 | 15 Amps at 12 Volts | 2 |
| 18520 | 2 | 20 Amps at 12 Volts | 2 |
| 18521 | 2 | 30 Amps at 12 Volts | 2 |
| 18522 | 2 | 40 Amps at 12 Volts | 2 |
| 15048 | 3 | 30 Amps at 12 Volts | 5 |
| 15049 | 3 | 40 Amps at 12 Volts | 5 |

HEAT SHRINK TUBING

Made in the U.S.A. • Photos not actual size



Black Thin Wall Heat Shrink Tubing

- 2 to 1 Shrink Ratio
- Cross linked Polyolefin
- Highly Flame Retardant (VW-1)

| Auveco Part No. | Size | Pre-Shrink I.D. | Post-Shrink I.D. | Length | Unit Pkg. |
|-----------------|--------|-----------------|------------------|--------|-----------|
| 18693 | 3/64" | .046" | .023" | 6" | 25 |
| 18694 | 1/16" | .063" | .031" | 6" | 25 |
| 18695 | 3/32" | .093" | .046" | 6" | 25 |
| 18696 | 1/8" | .125" | .062" | 6" | 25 |
| 18697 | 3/16" | .187" | .093" | 6" | 25 |
| 18698 | 1/4" | .250" | .125" | 6" | 25 |
| 18699 | 3/8" | .375" | .187" | 6" | 15 |
| 18700 | 1/2" | .500" | .250" | 6" | 15 |
| 18701 | 3/4" | .750" | .375" | 6" | 10 |
| 18702 | 1" | 1.00" | .500" | 6" | 10 |
| 18703 | 1-1/2" | 1.50" | .750" | 6" | 5 |



Adhesive Lined Heat Shrink Tubing

- 4.5 to 1 Shrink Ratio
- Cross linked, Semi-Rigid Polyolefin Outer Jacket
- Hot-Melt Adhesive Inner Wall adheres to all major types of Wire
- Environmentally Seals & Insulates
- Meets O.E.M. Specs: Ford: ESB M99 D56 A1 Chrysler: MS-DB56

| Auveco Part No. | Pre-Shrink I.D. | Post-Shrink I.D. | Length | Color | Unit Pkg. |
|-----------------|-----------------|------------------|--------|-------|-----------|
| 18705 | .225" | .050" | 3-1/2" | Black | 10 |
| 18706 | .293" | .065" | 3-1/2" | Black | 10 |
| 18707 | .427" | .095" | 3-1/2" | Black | 10 |
| 18708 | .700" | .175" | 3-1/2" | Black | 5 |



Adhesive Lined Dual Wall Self-Sealing Heat Shrink Tubing

- 3 to 1 Shrink Ratio
- Excellent Insulating, Abrasion-Resisting & Strain Relief Properties
- Provides Waterproofing & Environmental Protection

| Auveco Part No. | Size | Pre-Shrink I.D. | Post-Shrink I.D. | Length | Color | Unit Pkg. |
|-----------------|-------------|-----------------|------------------|--------|-------|-----------|
| 16665 | 22-14 Gauge | .188" | .062" | 12" | Black | 4 |
| 16666 | 12-10 Gauge | .250" | .083" | 12" | Black | 4 |
| 18733 | 14-10 Gauge | .400" | .150" | 6" | Black | 4 |
| 19102 | 14-10 Gauge | .400" | .150" | 6" | Black | 25 |
| 18734 | 14-10 Gauge | .400" | .150" | 6" | Red | 4 |
| 19103 | 14-10 Gauge | .400" | .150" | 6" | Red | 25 |
| 18735 | 8-1 Gauge | .750" | .220" | 6" | Black | 4 |
| 19104 | 8-1 Gauge | .750" | .220" | 6" | Black | 25 |
| 18736 | 8-1 Gauge | .750" | .220" | 6" | Red | 4 |
| 19105 | 8-1 Gauge | .750" | .220" | 6" | Red | 25 |
| 18737 | 2-4/0 Gauge | 1.100" | .375" | 6" | Black | 4 |
| 19106 | 2-4/0 Gauge | 1.100" | .375" | 6" | Black | 25 |
| 18738 | 2-4/0 Gauge | 1.100" | .375" | 6" | Red | 4 |
| 19107 | 2-4/0 Gauge | 1.100" | .375" | 6" | Red | 25 |

Heat Shrink Tubing Kit

| Auveco Part No. | Qty. | Pre-Shrink Size | Post-Shrink I.D. | I.D. |
|-----------------|------|-----------------|------------------|-------|
| 18697 | 36 | 3/16" | .187" | .093" |
| 18698 | 24 | 1/4" | .250" | .125" |
| 18699 | 12 | 3/8" | .375" | .187" |
| 18700 | 6 | 1/2" | .500" | .250" |
| 18701 | 4 | 3/4" | .750" | .375" |
| 18702 | 4 | 1" | 1.00" | .500" |

UNIT PACKAGE: 1

18887

Six inch lengths of black thin wall, cross linked polyolefin, heat shrink tubing in a durable translucent polypropylene box. The tubing has 2:1 shrink ratio.



FUSE HOLDERS & ACCESSORIES

Photos not actual size

Sec. 12

12592

Nylon



Glass Tube Fuse Puller

UNIT PACKAGE: 1

12079

Nylon



Moulded In-Line Fuse Holder with 8" of 18 Gauge Wire
Use with Auveco 1/4" x 1-1/4" Glass Tube Fuses
Up to and including 20 Amps

UNIT PACKAGE: 3

11618

Nylon



Fuse Assembly with 30 Amp Fuse Included
12 Gauge Wire

UNIT PACKAGE: 5

18103

Tests ATO® (Blade Type) and Mini-Fuses.

Now you can make sure the fuse is good before installing it.

Also functions as a fuse puller.
40 Amp maximum

UNIT PACKAGE: 1

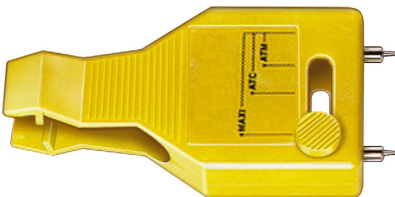

12359

In-Line Fuse Holder

Accommodates all ATO/ATC fuses from 3-30 Amps
Heavy Duty Hard Shell Construction
10" Loop of 14 Gauge Wire

UNIT PACKAGE: 3

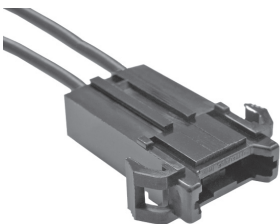

14055

In-Line Fuse Holder

Accommodates all ATO/ATC fuses from 3-30 Amps Heavy Duty Hard Shell Construction
10" Loop of 12 Gauge Wire

UNIT PACKAGE: 3

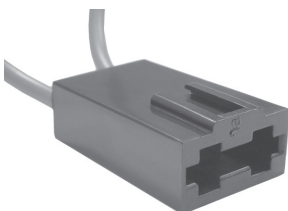

12363

In-Line Fuse Holder

Accommodates all ATO/ATC fuses from 3 thru 20 Amps.
Comes with two 4" 16 Gauge Wire Leads.

UNIT PACKAGE: 5

20789

In-Line Mini Fuse Holder



30 Amp Maximum
12 Gauge Wire

Use with Auveco Mini Fuses 16351-16360
Replaces Auveco 17648 Fuse NOT Included

UNIT PACKAGE: 3

12977

Self-Stripping Fuse Holder

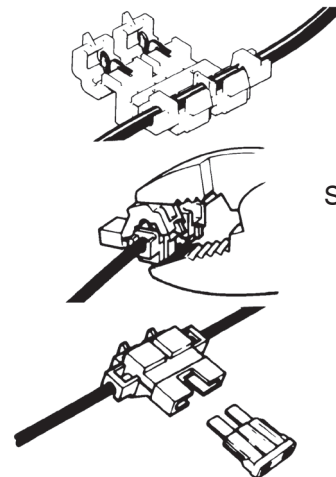

Mates with most plug-in blade type fuses found in late-model domestic and some import cars.
For 18-14 gauge copper wire.

32 volts maximum
20 amp maximum with 14 gauge wire
10 amp maximum with 16 gauge wire
7.5 amp maximum with 18 gauge wire

UNIT PACKAGE: 5

Photos not actual size

Sealed Fuse Holders For ATM Mini® Fuses



20206

20, 25 & 30 Amp Capacity
10" Long 12 Gauge Cross-Linked Polyethylene Leads
Fuse NOT Included

UNIT PACKAGE: 1



20207

2-15 Amp Capacity
10" Long 16 Gauge Cross-Linked Polyethylene Leads
Fuse NOT Included

UNIT PACKAGE: 1

High Power Sealed Fuse Holder

20320

For ATC & ATO Fuses
40 Amp Capacity
12" Long 10 Gauge 105 Strand
EZ Flex Wire Leads
Fuse NOT Included

UNIT PACKAGE: 1

Environmentally Sealed Blade Type Fuse Holder

Also used as Fuel Pump Fuse Holder on GM Vehicles

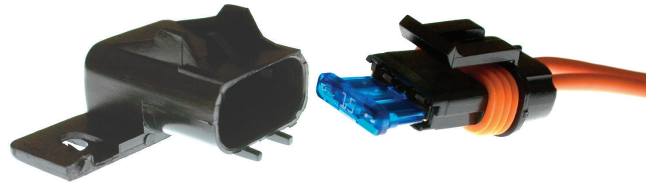

13686

(GM: 12101917; Delco: PT-189)

UNIT PACKAGE: 1

Electrical system protection for fleets, construction equipment, aircraft service vehicles, outdoor power equipment and marine installations.

Resistant to moisture, salt spray and engine compartment fluids. Withstands 50g physical shock. Operating temperature range from -40° to 125°C.

- Nylon Body with Latching Cap
- Silicone Rubber Seals at Wires and Cap
- 12 Gauge SE/GPT Wire Leads
- 3 to 30 Amp Capacity - Type ATC/ATO Fuses
- 5" Long Wire Leads
- Fuses NOT included

Low Profile JCase Fuses



| Auveco Part No. | Amp Rating | Color | Unit Pkg. |
|-----------------|------------|--------|-----------|
| 21472 | 20 | Blue | 3 |
| 21473 | 25 | White | 3 |
| 21474 | 30 | Pink | 3 |
| 21106 | 40 | Green | 3 |
| 21475 | 50 | Red | 3 |
| 21476 | 60 | Yellow | 3 |

PAL™ (Pacific Auto Link) Fuses



Type 1

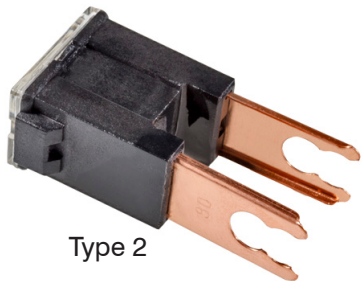

Type 2



Type 3



Type 4

| Auveco Part No. | Type | Amp Rating | Color | Unit Pkg. |
|-----------------|------|------------|--------|-----------|
| 20560 | 1 | 20 | Blue | 1 |
| 15926 | 1 | 30 | Pink | 1 |
| 15927 | 1 | 40 | Green | 1 |
| 19294 | 1 | 50 | Red | 3 |
| 15928 | 1 | 60 | Yellow | 1 |
| 15929 | 2 | 30 | Pink | 1 |
| 15930 | 2 | 60 | Yellow | 1 |
| 15931 | 2 | 80 | Black | 1 |
| 15932 | 3 | 30 | Pink | 1 |
| 15933 | 3 | 40 | Green | 1 |
| 19295 | 3 | 80 | Black | 2 |
| 19296 | 3 | 100 | Blue | 2 |
| 20551 | 4 | 20 | Blue | 2 |
| 20552 | 4 | 30 | Pink | 2 |
| 20553 | 4 | 40 | Green | 2 |
| 20554 | 4 | 50 | Red | 2 |
| 20555 | 4 | 60 | Yellow | 2 |

Photos not actual size

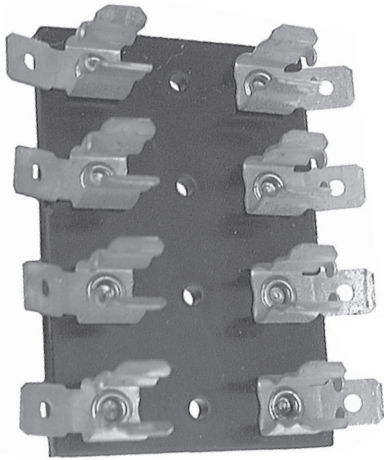

13445

Four Gang Fuse Block

Size: 2-7/16" x 2-15/16" x 3/4"

For use with SFE-20 Amp. fuse or any 3 AG series fuse. Phosphor bronze fuse clips. Brass screws

UNIT PACKAGE: 1

Terminal/Junction Blocks



For marine and exposed applications. Brass nickel plated terminal links and binding head terminal screws. Moisture repellent molded ABS base with protective insulator barrier strips. 20 Amp rating.

13446

4 Gang (Circuits)

Size: 3-1/4" x 1-5/16" x 5/8"

UNIT PACKAGE: 1

13447

6 Gang (Circuits)

Size 3-3/8" x 1-1/8" x 9/16"

UNIT PACKAGE: 1

13449

10 Gang (Circuits)

Size: 5-1/8" x 1-1/8" x 9/16"

UNIT PACKAGE: 1



14474

Blade Type Fuse Tap

A quick, easy alternative to direct wiring when tapping the "hot side" of the fuse block. The blade type fuse tap is made of sturdy brass and is engineered for quick connect and disconnect of accessories such as C.B. radios, hand-held lights, etc.

UNIT PACKAGE: 25

Installation can be completed in three steps:

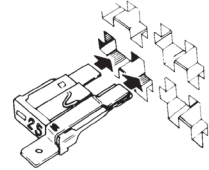
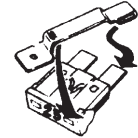

1. Use a test probe to locate the "hot side" of the circuit in the fuse block. Then snap the tap over the corresponding "hot side" blade of the fuse. Insert the fuse into the fuse block.

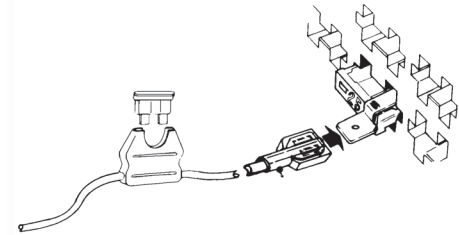

2. Crimp one end of an in-line fuse holder (with the fuse installed) to a fully insulated nylon .250" female quick-connect terminal. Attach the other fuse holder lead to the accessory wire.

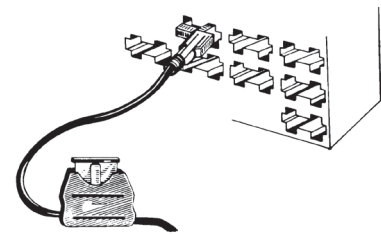

3. Complete the connection by sliding the female quick-connect terminal onto protruding tab of the tap.



17686

Mini Fuse Blade Type Fuse Tap

"Tapping" fuse blocks equipped with Mini® Fuses are no Problem!

Now there's a quick, easy alternative to direct wiring for tapping the "hot side" of mini fuse style fuse blocks. The blade type fuse tap is made of .016" thick sturdy brass with a .187" (3/16") wide tab. It is engineered for quick connect and disconnect of accessories.

UNIT PACKAGE: 50

Installation can be complete in 3 steps:



1. Locate "hot side" of circuit in fuse block with a test probe. Slide the tap onto corresponding "hot side" blade of fuse.

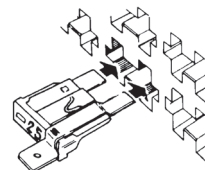

2. Insert the fuse into the fuse block

3. Crimp one end of an in-line fuse holder (with the fuse installed) to the appropriate Auveco female connector 8781 (16-14 Ga.) or 12159 (22-18 Ga.). Attach the other fuse holder lead to the accessory wire. Slide the female connector onto protruding tab of the tap.

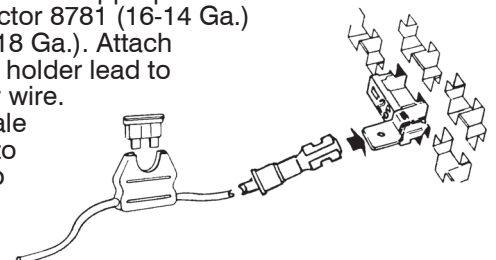

**ATC®/ATO®
(Blade Type) Fuses**



| Auveco Part No. | | Amp Rating | Color |
|-----------------|-----------------|------------|--------|
| Unit Pkg. 5 | Unit Pkg. 25 | | |
| 12534 | 12548 | 3 | Violet |
| 12535 | 12549 | 4 | Pink |
| 12536 | 12550 | 5 | Tan |
| 12537 | 12551 | 7-1/2 | Brown |
| 12538 | 12552 | 10 | Red |
| 12539 | 12553 | 15 | Blue |
| 12540 | 12554 | 20 | Yellow |
| 12541 | 12555 | 25 | White |
| 12542 | 12556 | 30 | Green |

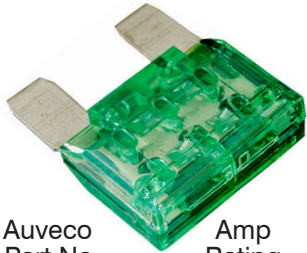

**Maxi™
Fuses**

| Auveco Part No. | Amp Rating | Color | Unit Pkg. |
|-----------------|------------|--------|-----------|
| 15505 | 20 | Yellow | 2 |
| 15506 | 30 | Green | 2 |
| 15507 | 40 | Orange | 2 |
| 15508 | 50 | Red | 2 |
| 15509 | 60 | Blue | 2 |



**Low Profile
Mini Fuses**

| Auveco Part No. | Amp Rating | Color | Unit Pkg. |
|-----------------|------------|--------|-----------|
| 21602 | 5 | Tan | 5 |
| 21603 | 7.5 | Brown | 5 |
| 21436 | 10 | Red | 5 |
| 21437 | 15 | Blue | 5 |
| 21166 | 20 | Yellow | 5 |
| 21438 | 25 | Clear | 5 |
| 21604 | 30 | Green | 5 |

Mega® Fuses



| Auveco Part No. | Amp Rating | Unit Pkg. |
|-----------------|------------|-----------|
| 21598 | 40 | 2 |
| 21599 | 60 | 2 |
| 21600 | 80 | 2 |
| 18986 | 100 | 2 |
| 18987 | 125 | 2 |
| 18988 | 150 | 2 |
| 18989 | 175 | 2 |
| 18990 | 200 | 2 |
| 22118 | 250 | 2 |
| 22119 | 300 | 2 |
| 22120 | 500 | 2 |

FUSES

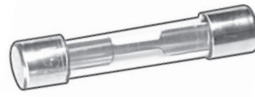

**Glass Tube
Fuses**

| Auveco Part No. | Size | Amp | Code | Unit Pkg. |
|-----------------|----------------|-----|---------|-----------|
| 18981 | 1/4" x 1-1/4" | 2 | AGC-2 | 5 |
| 17625 | 1/4" x 1-1/4" | 3 | AGC-3 | 5 |
| 17626 | 1/4" x 1-1/4" | 5 | AGC-5 | 10 |
| 17627 | 1/4" x 1-1/4" | 7.5 | AGC-7.5 | 10 |
| 12545 | 1/4" x 1-1/4" | 10 | AGC-10 | 5 |
| 12546 | 1/4" x 1-1/4" | 15 | AGC-15 | 5 |
| 18982 | 1/4" x 1-1/4" | 20 | AGC-20 | 5 |
| 12543 | 1/4" x 1-1/4" | 20 | SFE-20 | 5 |
| 18983 | 1/4" x 1-1/4" | 25 | AGC-25 | 5 |
| 12544 | 1/4" x 1-7/16" | 30 | SFE-30 | 5 |
| 12547 | 1/4" x 1-1/4" | 30 | AGC-30 | 5 |



Mini® Fuses

| Auveco Part No. | Amp Rating | Color | Unit Pkg. |
|-----------------|------------|--------|-----------|
| 16351 | 2 | Gray | 5 |
| 16352 | 3 | Purple | 5 |
| 16353 | 4 | Pink | 5 |
| 16354 | 5 | Tan | 5 |
| 16355 | 7.5 | Brown | 5 |
| 16356 | 10 | Red | 5 |
| 16357 | 15 | Blue | 5 |
| 16358 | 20 | Yellow | 5 |
| 16359 | 25 | White | 5 |
| 16360 | 30 | Green | 5 |



**Micro Fuses
2 Blades**

| Auveco Part No. | Amp Rating | Color | O.E.M No. | Unit Pkg. |
|-----------------|------------|---------|--------------|-----------|
| 21828 | 5 | Tan | GM: 19209790 | 5 |
| 21829 | 7.5 | Brown | GM: 19209791 | 5 |
| 21830 | 10 | Red | GM: 19209792 | 5 |
| 21831 | 15 | Blue | GM: 19209793 | 5 |
| 21832 | 20 | Yellow | GM: 19209794 | 5 |
| 21833 | 25 | Natural | GM: 19209795 | 5 |
| 21834 | 30 | Green | GM: 19209796 | 5 |



**Micro Fuses
3 Blades**

| Auveco Part No. | Amp Rating | Color | O.E.M No. | Unit Pkg. |
|-----------------|------------|-------|------------------------------------|-----------|
| 21749 | 5 | Tan | Ford: DG9Z-14526-N GM: 19209797 | 2 |
| 21750 | 7.5 | Brown | Ford: DG9Z-14526-S GM: 19209798 | 2 |
| 21751 | 10 | Red | Ford: DG9Z-14526-P GM: 19209799 | 2 |
| 21752 | 15 | Blue | Ford: DG9Z-14526-R GM: 19119304 | 2 |

Use with butt connectors on pages 205-211 • *Photos not actual size*



9905

(Chry: 2496279; GM: 2973932;
AMC: 3509575; IHC: 374985C1)

Instrument Panel Socket for 5/8" Hole
Bulb No. 158, 194, 194A
GM, Chrysler, AMC & International

UNIT PACKAGE: 10



12237

(Chry: 3744750; GM: 12004311,
25015169; Ford: C80Z-13711A)

Instrument Panel Socket for 1/2" Hole
Bulb No. 158, 194, 194A
GM, Ford & Chrysler

UNIT PACKAGE: 2



9883

(GM: 6298886,
6298892, 6298935;
Ford: D0DZ-15A434B)

Side Marker Assembly
Bulb No. 158, 194, 194A
GM & Ford

UNIT PACKAGE: 5

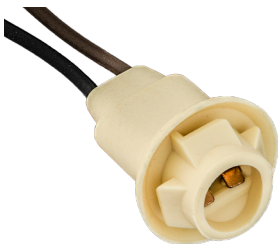

11441

Instrument Panel and
Marker Lights
Bulb No. 158, 194, 194A
GM & Ford

UNIT PACKAGE: 10

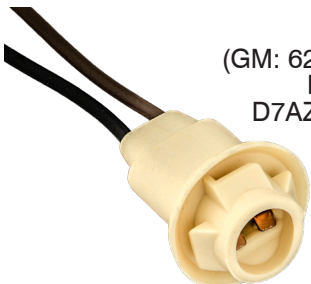

11166

(GM: 6294015, 8901283, 8918527;
Ford: D40Z-13410E,
D7AZ-13412A, D7FZ-13412A)

Side Marker and
License Plate Lights
Bulb No. 158, 194, 194A
GM & Ford

UNIT PACKAGE: 1



13540

(8912750)

Side Marker, License,
Parking & Tail Lights
Bulb No. 158, 194, 194A
GM

UNIT PACKAGE: 1

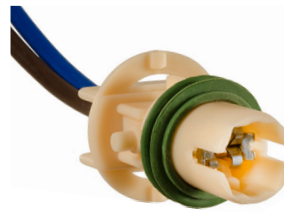

17108

(12083007)

Marker Light Pigtail
Bulb No. 24
GM 1988-On

UNIT PACKAGE: 1

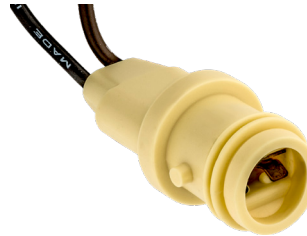

18924

(12083460)

Rear Side Marker Lights
Bulb No. 158, 194, 194A
GM 1985-On

UNIT PACKAGE: 1

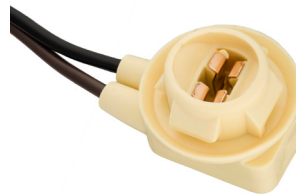

13549

(12001470)

Side Marker, License,
Tail & Stop Lights
Bulb No. 158, 194, 194A
GM

UNIT PACKAGE: 1

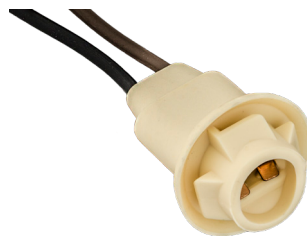

13558

(6298892, 6298886)

Side Marker Assembly
Bulb No. 158, 194, 194A
GM

UNIT PACKAGE: 1



8755

(2978302)

License Plate, Back-Up
& Instrument Panel Lights
For 1-1/8" Hole
Bulb No. 63, 67, 81, 87, 89, 93,
209, 1003, 1073, 1129, 1133 & 1141
GM

UNIT PACKAGE: 10

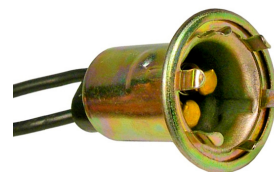

8759

Signal, Park, Stop
& Tail Lights
For 3/4" Hole
Bulb No. 198, 1016,
1034, 1154 & 1157
GM

UNIT PACKAGE: 5

Use with butt connectors on pages 205-211 • *Photos not actual size*



8756

(2974309)

Signal, Park, Stop & Tail Lights
For 1-1/8" Hole
Bulb No. 198, 1016, 1034, 1154 & 1157
GM

UNIT PACKAGE: 10



13544

(12003878, 8904251)

Back-up, Cornering
& Turn Signal
Bulb No. 1156
GM

UNIT PACKAGE: 1



8754

Weatherproof Signal,
Park, Stop & Tail Lights
For 3/4" Hole
Bulb No. 198, 1016, 1034, 1154 & 1157
GM

UNIT PACKAGE: 5

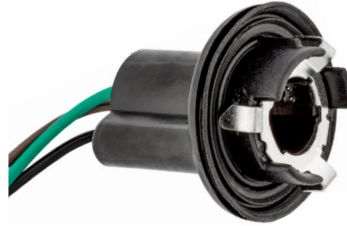

11446

(8902487, 8903283,
8907701 & 8909908)

Stop & Tail Lights
Bulb No. 1157
GM

UNIT PACKAGE: 5

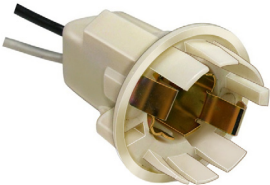

8750

(2974309, 2983540,
6299087 & 8912698)

Signal, Park, Stop & Tail Lights
Bulb No. 1034, 1154 & 1157
GM

UNIT PACKAGE: 5

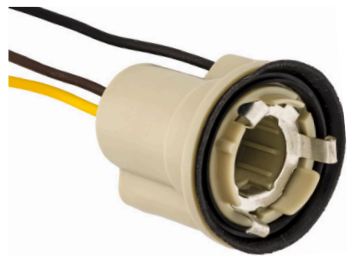

11154

(8903202, 8914822)

Park, Stop & Tail Lights
Bulb No. 1034,
1154 & 1157
GM

UNIT PACKAGE: 1

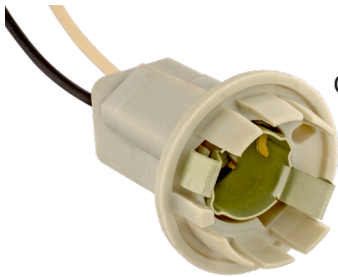

11157

(AMC: 4486948;
GM: 2983540, 8912698;
6299087)

Signal, Park, Stop
& Tail Lights
Bulb No. 1034,
1154 & 1157
GM & AMC

UNIT PACKAGE: 1



11475

(8903202, 8914822)

Park, Stop & Tail Lights
Bulb No. 1034, 1154 & 1157
GM

UNIT PACKAGE: 5

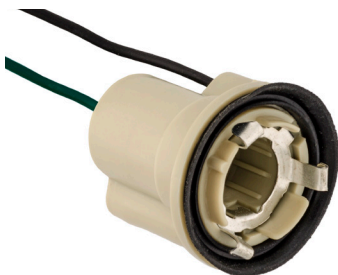

11156

(GM: 5963268,
8904437, 8909518;
IHC: 57172C91)

Back-up & Cornering
Bulb No. 1156
GM & IHC

UNIT PACKAGE: 1



21006

(15306157)

White Shell, Natural Insert

Daytime Running Lights
& Turn Signal
Bulb No. 3156 & 4156
GM 1999 - On

UNIT PACKAGE: 1

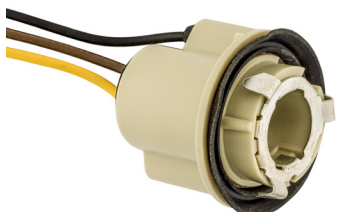

11476

(8903203, 8914823)

Park, Stop & Tail Lights
Bulb No. 1157
GM

UNIT PACKAGE: 5

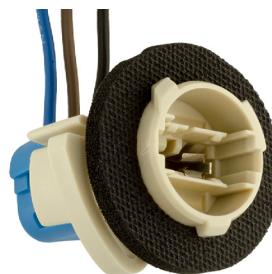

17175

(12076946)

Ivory Shell

Stop, Tail, Turn &
Parking Lights
Bulb No. 3057 & 3157
GM 1988-On

UNIT PACKAGE: 1

GM SOCKET ASSEMBLY & HARNESS CONNECTORS

Use with butt connectors on pages 205-211 • *Photos not actual size*

Sec. 12

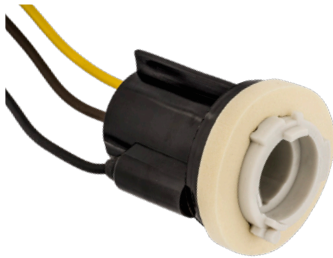

13543
(8919916,12013813)

Park, Stop &
Tail Lights
Bulb No. 1157
GM

UNIT PACKAGE: 1

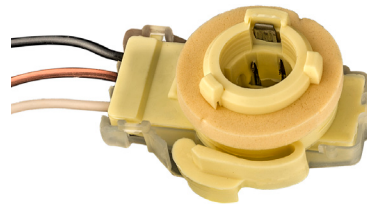

13546
(12003757)

Signal & Park Lights
Bulb No. 198 & 2057
GM

UNIT PACKAGE: 1



16585
(12083005)

Signal, Park, Stop & Tail Lights
Dual Filament Wedge Base
Bulb No. 3057
GM

UNIT PACKAGE: 1

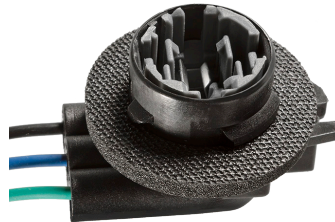

17172
(12083680)
Black Shell

Stop, Tail, Turn
& Parking Lights
Bulb No. 3057 & 3157
GM: 1989-On

UNIT PACKAGE: 1



16586
(12083006)

Signal, Park, Stop &
Tail Lights
Dual Filament Wedge Base
Bulb No. 3057
GM

UNIT PACKAGE: 1



17173
(12083689)
Ivory Shell

Stop, Tail, Turn
& Parking Lights
Bulb No. 3057 & 3157
GM 1990-On

UNIT PACKAGE: 1



18923
(12027133)

Back-Up Lights
GM 1982-On

UNIT PACKAGE: 1



17174
(12085330)
Brown Shell

Back-Up Lights
Bulb No. 2456 & 3156
GM 1990-On

UNIT PACKAGE: 1

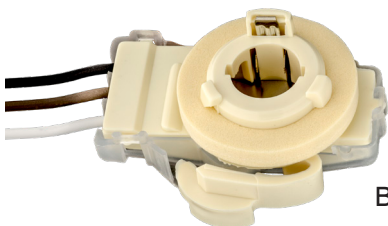

12600
(GM: 12003759;
AMC: 812893)

90° Pigtail &
Socket Assembly
Bulb No. 1016, 1034,
1154 & 1157
GM & AMC

UNIT PACKAGE: 1



14918
(12048369)

Headlight Socket Assembly
for High-Low 9004 & 9007
Halogen Bulb
GM, Ford & Imports

UNIT PACKAGE: 1

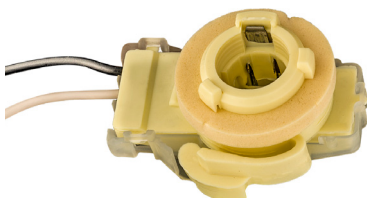

13545
(12003758)

Tail Lights
Single Contact
Bulb No. 87, 93 & 1156
GM

UNIT PACKAGE: 1

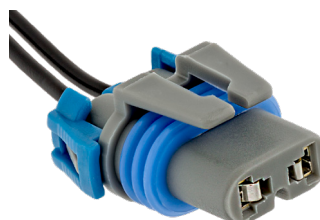

16174

Headlight Socket Assembly
For Low Beam 9006
Halogen Bulb
Single Indexing Groove
GM, Ford, AMC & Imports

UNIT PACKAGE: 4

Use with butt connectors on pages 205-211 • *Photos not actual size*

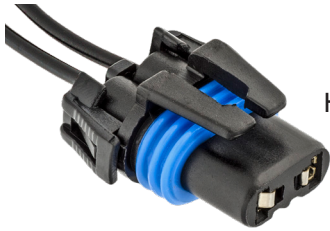

16175
(GM: 12101898)

Headlight Socket Assembly
For High Beam 9005
Halogen Bulb
Two Indexing Grooves
GM, Ford, AMC & Imports

UNIT PACKAGE: 4



18867
(12101880)

Direct Ignition
Harness Connector
GM
1987-On

UNIT PACKAGE: 1

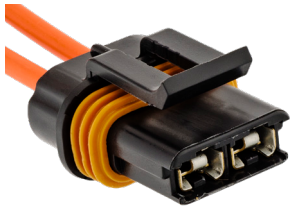

16967
(12101906)

Heater Blower connector
pigtail on GM 1985-On.
Can also be used as
an ATO/ATC Fuse Holder.
Features two 9" long 12 gauge
GXL wire leads.

UNIT PACKAGE: 1

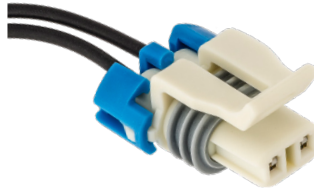

18318
(12101857)

Air Divert Valve
Harness Connector
GM 1994-87

UNIT PACKAGE: 1

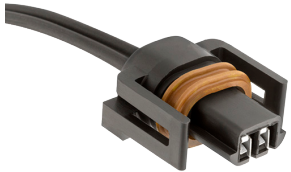

17114
(12085496)

Direct Ignition Throttle
Body Injection Pigtail
GM 1987-On

UNIT PACKAGE: 2

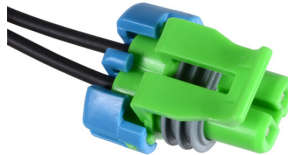

18320
(12101856)

Air Switch Valve
Harness Connector
GM 1993-91

UNIT PACKAGE: 1



17112
Not Supplied By O.E.M.

Distributor Module Pigtail
Used on GM distributor
module 1987466
on 6 cylinder 2.8 engines
1985-On

UNIT PACKAGE: 1



18524
(12085497)

MAP Mass Air Flow Sensor
Harness Connector
GM with 2.8 Eng &
Sequential Fuel Injection
1989-85

UNIT PACKAGE: 1

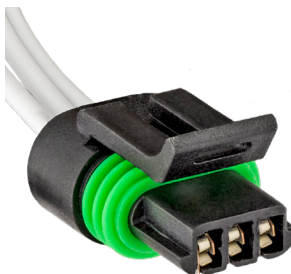

18916
(12085483)

Ignition Module, Crankshaft
Coolant Sensor & Power
Steering Pressure Switch
Harness Connector
GM 1986-On

UNIT PACKAGE: 1



18868
(12085495)

Mass Air Flow Sensor
Harness Connector
GM 1988-On

UNIT PACKAGE: 1

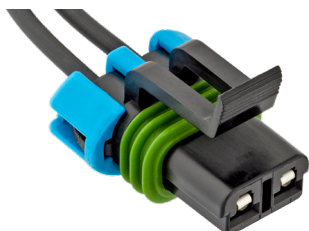

18870
(12101855)

Direct Ignition
Vehicle Speed Sensor
Harness Connector
GM
1987-On

UNIT PACKAGE: 1

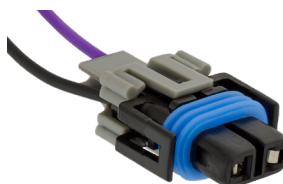

16694
(12043215, 12085498)

Cornering & Fog Light Socket
for 881 & H11 Halogen Bulbs
GM

UNIT PACKAGE: 1

GM SOCKET ASSEMBLY & HARNESS CONNECTORS

Sec. 12

Use with butt connectors on pages 205-211 • *Photos not actual size*



21490

(GM: 12102664,88862264)
(Ford: 1U2Z-14S411-YA)

Fog & Front Lights, Power Steering & Oil Pressure Switch Harness Connector
GM 2005 - 1986
Ford 2004 - 1995
Jeep Eagle 1994

UNIT PACKAGE: 1

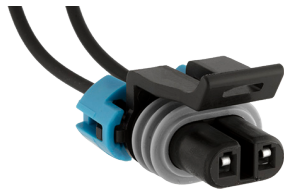

17110

(12102747)

Windshield Washer Pump, Low Coolant Sensor Harness Connector
GM Cars & Trucks 1992-87

UNIT PACKAGE: 1

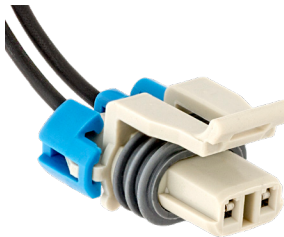

17111

(12116958)

Horn Harness Connector
Fits Horns 1999160, 1999161, 10456327 and 10456328
GM 1988-On

UNIT PACKAGE: 1



21212

(88988609)

Window Motor Regulator Harness Connector
Two 12 Gauge
10" Long Leads
GM 1995 - On

UNIT PACKAGE: 1

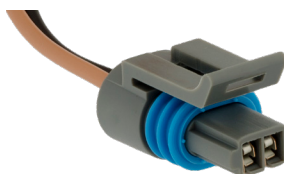

16693

(12046624, 12102620)

Replacement harness connector used with 1985-on GM Manifold

Air Temperature Sensors including 25036751. Features two 9" long 18 gauge wire leads.

UNIT PACKAGE: 1



18917

(12085538)

Camshaft Sensor Harness Connector
Buick, Olds & Pontiac
1992-86

UNIT PACKAGE: 1



18925

(25117765)

E.F.I. Fuel Pump Harness Connector
GM with Fuel Pump in Gas Tank 1995-88

UNIT PACKAGE: 1

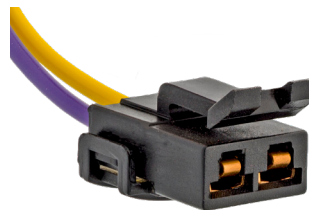

19891

(Not Available from O.E.M.)

Windshield Wiper Motor Harness Connector
GM 1994 - 86

UNIT PACKAGE: 1

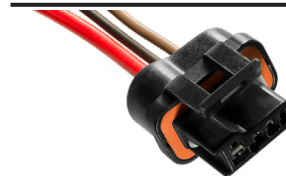

17109

(12085525, 12085527, 12085528, 12101895, 12117361)

3 Wire Alternator Harness Connector
Two 18 gauge and one 12 gauge leads
Can be used to replace two wire and single wire harness connectors by taping (do NOT cut) the appropriate unused leads.

GM 1986-On

UNIT PACKAGE: 1

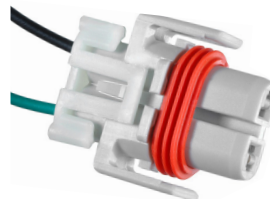

21220

(GM: 88987187)

Headlight Socket Harness Connector for H9 Halogen Bulb (Auveco Bulb No. BH9)

GM, Audi, Mazda, Mini-Cooper, Porsche, Volkswagen & Volvo

UNIT PACKAGE: 1



17113

(12101937)

A.C. Compressor Clutch Harness Connector
GM Cars & APV 1989-On

UNIT PACKAGE: 1



16514

(12085503)

Replacement harness connector used on GM V-5 Air Conditioning Compressor Pressure Cut-off Switches. Fits GM low Pressure Switch 6551946 and others. Index slot is at three o'clock position. Features two 9" long 18 gauge wire leads

UNIT PACKAGE: 1

Use with butt connectors on pages 205-211 • *Photos not actual size*

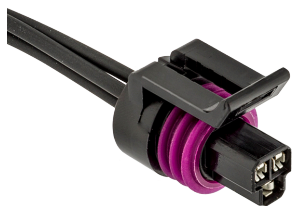

18527
(12102748)

Throttle Position Sensor
Harness Connector
GM 1994-90

UNIT PACKAGE: 1



14580
(12102621)

Radiator Fan Sensor Switch
Harness Connector
Fits electric cooling fan switches:
3040674, 14043275 and 14043276
GM 1980-On

UNIT PACKAGE: 1



18674
(12126451)

Coolant Temperature
Sensor Harness Connector
Fits Sensor 10232601 & 25037203
GM 1987-On

UNIT PACKAGE: 1

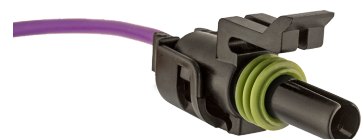

17107
(12117385)

Oxygen Sensor
Connector Pigtail
Fits the Following Oxygen Sensors:
8990469 (AC-Delco AFS13P)
8990625 (AC-Delco AFS15P)
8990741 (AC-Delco AFS16P)
10042186 (AC-Delco 213-15)
25105107 (AC-Delco AFS20)
25105901 (AC-Delco AFS21)
25106073 (AC-Delco AFS22)
Most GM Models 1982-On

UNIT PACKAGE: 1



16962
(Not Supplied by O.E.M.)

Harness Connector used with GM
Mixture Control Solenoid Kits:
17067343, 17067344 and
17111102 on
2 & 4 barrel Rochester
Varajet Carburetors.
GM cars and trucks 1980-On

UNIT PACKAGE: 1



19882
(12085485)

Back-Up Light Switch &
Speed Sensor Harness Connector
Used with Switch 23049569,
PT107 & IACV Motor
GM 1971-On

UNIT PACKAGE: 1

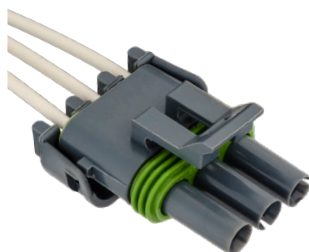

16965
(12085507)
Gray

Air Conditioner Pressure
Switch Harness Connector
Used on GM vehicles
(28 models) 1988-84

UNIT PACKAGE: 1

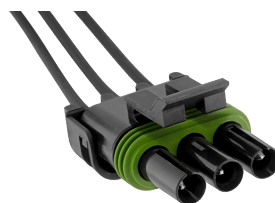

17198
(Not Supplied by O.E.M.)

Throttle Position Sensor
Harness Connector
Fits Sensor 17078051,
17078448 & 17078481 on
2 & 4 Barrel Rochester Carburetors
GM 1990-80

UNIT PACKAGE: 1

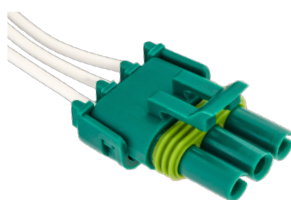

16964
(12085502)
Green

Manifold Absolute Pressure
(MAP) Harness Connector.
Fits GM MAP Sensor 6137039
on GM vehicles (38 models)
1982-on

UNIT PACKAGE: 1

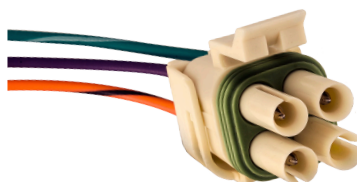

17199
(12085533)

Transmission
Converter Clutch
Harness Connector

3 Wires (Cavity "C" is not wired)
GM 1990-84

UNIT PACKAGE: 1

GM SOCKET ASSEMBLY & HARNESS CONNECTORS

Use with butt connectors on pages 205-211 • *Photos not actual size*

Sec. 12



18918

(12085506)

Fuel Injection
Idle Air Control Valve,
Stoplight Switch & Torque
Converter Clutch Valve
Harness Connector
GM 1985 - On

UNIT PACKAGE: 1



16968

(12085491)

Fuel Injector
Solenoid Harness Connector
Fits GM Multi-Port Fuel
Injector 1711799 on 2.8
and 3.1 liter engines
(27 models) 1986 - On
Fits Fuel Injectors on Ford,
Chrysler & Imports (Bosch)

UNIT PACKAGE: 1

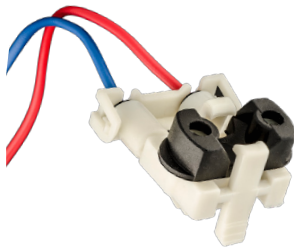

17463

(12102568)

Fuel Injector Connector for
TBI (Throttle Body Injector)
Systems
All GM (Including
Trucks) 1978 - On

UNIT PACKAGE: 1



17690

(12101903)

Washer Fluid Sensor
Harness Connector
Also used on Back-Up
Light Switch & A.C. Compressor Switch
GM 1985-On

UNIT PACKAGE: 5

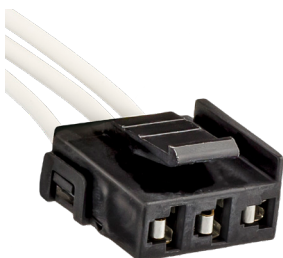

19556

(12117354)

Harness Connector
Brake Light Switch 25529862
GM: Camaro, Caprice,
Century, Firebird, Lumina APV,
K,S, & T Truck, Silhouette &
Trans Sport 1991 - On

UNIT PACKAGE: 1



18525

(Not Supplied by O.E.M.)

Tail Light
Harness Connector
GM Full Size Pick-Up
Trucks 1995 - 88

UNIT PACKAGE: 1

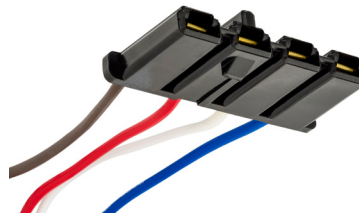

11444

Voltage Regulator
Pigtail
GM

UNIT PACKAGE: 10



21033

(88953358)

Harness Connector
For Blower Motor Resistors 89019088, 89019089 &
89019100 and Various Relays, Switches & Actuators
8" Leads
GM Cars and Light & Medium Duty Trucks 1990 - On

UNIT PACKAGE: 1



21542

(GM: 88953358)

Harness Connector with Seven 12 Gauge, 12" Leads
For Blower Motor Resistors 89019088, 89019089 &
89019100 and Various Relays, Switches & Actuators
GM Cars and Light & Medium Duty Trucks 1990 - On

UNIT PACKAGE: 1



19554

(12101927)

Harness Connector Headlight
and Ignition Switches
15693540, 10471139,
1070881, 26693547 & 15693548
GM: Astro, Safari, C, K, S, T Trucks,
Kodiak & Grand Am 1990-On

UNIT PACKAGE: 1



11440

(GM: 2962510)

Air Conditioner Blower Relay
Harness Connector
18 Gauge Wire
GM, AMC & Chrysler

UNIT PACKAGE: 10

Use with butt connectors on pages 205-211 • *Photos not actual size*

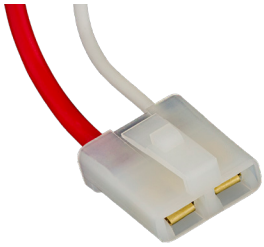

11443
(6294493)

Alternator Harness Connector with Transistorized Alternators GM

UNIT PACKAGE: 10

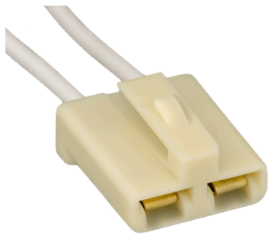

17691
(12101909)

Alternator Harness Connector Two 16 Gauge Leads Fits Delcotron Models 10-SI, 12-SI, 15-SI & 27-SI with Internal Voltage Regulator GM 1980-71

UNIT PACKAGE: 5

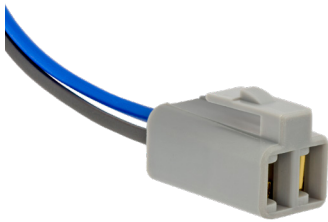

11442
(2977373)

Alternator Harness Connector with External Voltage Regulators GM 1977-62

UNIT PACKAGE: 10



13547
(2977373)

Alternator Extender Harness Connector with Female Connector GM 1974-62

UNIT PACKAGE: 2



13548
(6294493)

Alternator Extender Harness Connector with Female Connector GM 1971-On

UNIT PACKAGE: 2

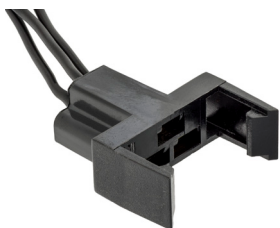

11436

Dimmer Switch Harness Connector GM

UNIT PACKAGE: 10

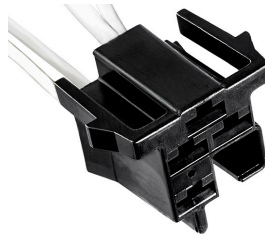

19555
(12102757)

Harness Connector Headlight Dimmer Switch GM Most Models 1990-On

UNIT PACKAGE: 1

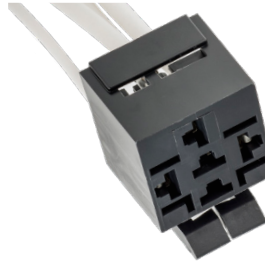

18871
(12101939)

Harness Connector for Cooling Fan, Fuel Pump, Starter Interrupt Relay & Fan Control Switch Cadillac 1988-On

UNIT PACKAGE: 1

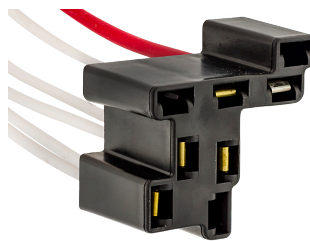

18530

(Not Supplied by O.E.M)

Headlight Switch Harness Connector Fits Switch 1995217 GM 1991-68

UNIT PACKAGE: 1

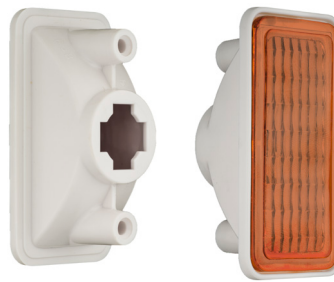

9884

(916638, 916581)
Plastic

Amber Lens Front Fender Marker Lamp Assembly Use with Auveco 9883 GM

UNIT PACKAGE: 1



9885

(916638, 916581)
Plastic

Clear Lens Front Fender Marker Lamp Assembly Use with Auveco 9883 GM

UNIT PACKAGE: 1

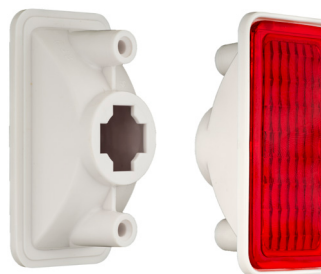

9916

(916632)
Plastic

Red Lens Rear Quarter Marker Lamp Assembly Use with Auveco 9883 GM

UNIT PACKAGE: 1

Use with butt connectors on pages 205-211 • *Photos not actual size*



12237
 (Chry: 3744750; GM: 12004311, 25015169; Ford: C80Z-13711A)
 Instrument Panel Socket for 1/2" Hole
 Bulb No. 194
 GM, Ford & Chrysler

UNIT PACKAGE: 2

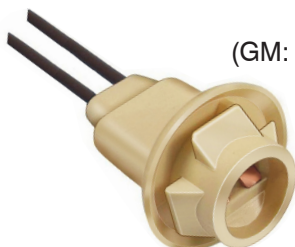

9883
 (GM: 6298886, 6298892, 6298935; Ford: D0DZ-15A434B)
 Side Marker Assembly
 Bulb No. 158, 194, 194A
 GM & Ford

UNIT PACKAGE: 5

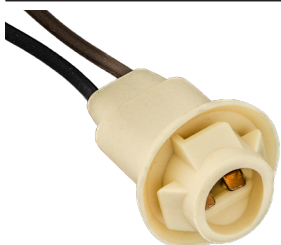

11441
 Instrument Panel and
 Marker Lights
 Bulb No. 158, 194, 194A
 GM & Ford

UNIT PACKAGE: 10

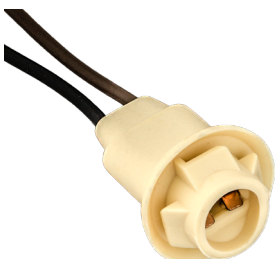

11166
 (GM: 6294015, 8901283, 8918527; Ford: D40Z-13410E, D7AZ-13412A, D7FZ-13412A)
 Side Marker &
 License Plate Lights
 Bulb No. 158, 194, 194A
 GM & Ford

UNIT PACKAGE: 1



8761
 License Plate & Instrument
 Panel Lights
 For 5/8" Hole
 Bulb No. 51, 53, 55, 57 & 57X
 Ford

UNIT PACKAGE: 10

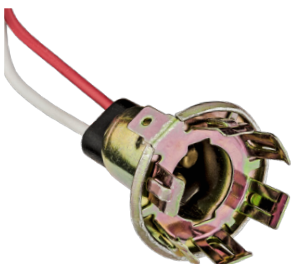

13537
 (D1AZ-13410B)
 Stop & Tail Lights
 with one Ground Male
 Blade Terminal
 Bulb No. 1034, 1154 & 1157
 Ford

UNIT PACKAGE: 1

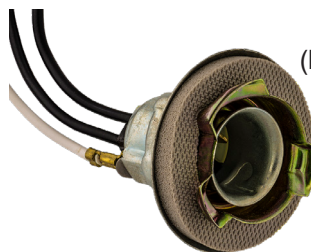

13533
 (D3AZ-13410B, D5DZ-13410A)
 Rear Lights
 Bulb No. 1157
 Ford

UNIT PACKAGE: 1



13535
 (D3AZ-13410A)
 Signal, Stop & Tail Lights
 Bulb No. 1156
 Ford

UNIT PACKAGE: 1

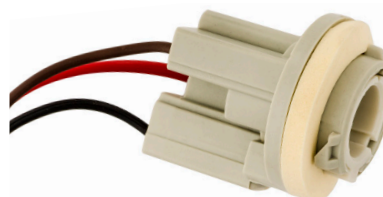

14133
 (D4LY-13410-A)
 Tail & Stop Lights
 Bulb No. 1157
 Ford

UNIT PACKAGE: 1

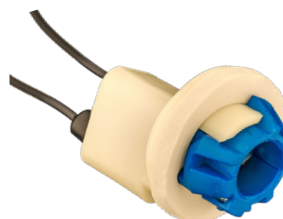

14131
 (D3AZ-13410-E)
 Back-up/Cornering Lights
 Bulb No. 1141
 Ford

UNIT PACKAGE: 1

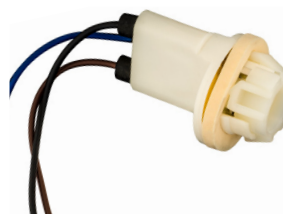

14128
 (D40Z-13234-A)
 Signal & Parking Lights
 Bulb No. 1157
 Ford

UNIT PACKAGE: 1

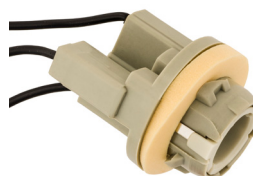

14132
 (D3AZ-13410-G)
 Tail & Stop lights
 Bulb No. 1157
 Ford

UNIT PACKAGE: 1



14135
 (D1FZ-13234-A)
 Parking Lights
 Bulb No. 1157
 Ford

UNIT PACKAGE: 1

Use with butt connectors on pages 205-211 • *Photos not actual size*

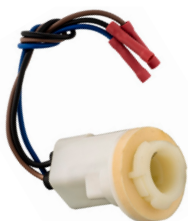

14130
(D4ZZ-13234-A)

Signal & Parking Lights
Bulb No. 1157
Ford

UNIT PACKAGE: 1

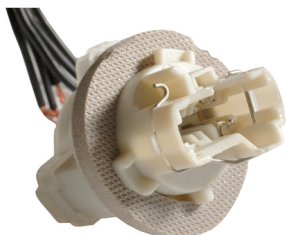

20837
(Not Supplied by O.E.M.)

Stop & Tail Light
Three 20 Gauge
Wire Leads
Uses 2458, 3057 &
3157 Wedge Type Bulbs
Ford 1987 - On

UNIT PACKAGE: 1



20848
(Not Supplied by O.E.M.)

Rear Light Assembly
Harness Connector
Four 18 Gauge Wire Leads
Ford F250 thru F750 without Pick Up Box 1999 - On

UNIT PACKAGE: 1

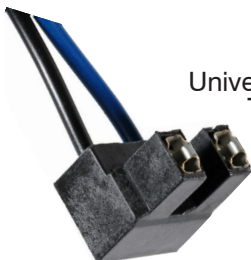

21210
(Not Available from O.E.M.)

Universal Headlight Harness Connector
Two 18 Gauge 6" Long Leads
For H7 Halogen Bulbs
Ford, Audi, BMW, Hyundai,
Kia, Mazda, Mercedes,
Mini Cooper, Saab & Subaru

UNIT PACKAGE: 1

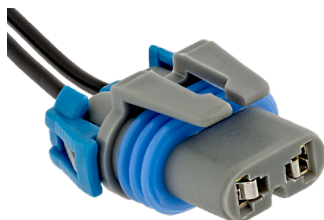

16174

Headlight Socket Assembly
For Low Beam 9006
Halogen Bulb
Single Indexing Groove
GM, Ford, AMC & Imports

UNIT PACKAGE: 4

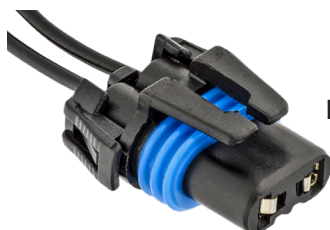

16175
(GM: 12101898)

Headlight Socket Assembly
For High Beam 9005
Halogen Bulb
Two Indexing Grooves
GM, Ford, AMC & Imports

UNIT PACKAGE: 4



21490

(GM: 12102664, 88862264)
(Ford: 1U2Z-14S411-YA)

Fog & Front Lights,
Power Steering & Oil Pressure
Switch Harness Connector
GM 2005 - 1986
Ford 2004 - 1995
Jeep Eagle 1994

UNIT PACKAGE: 1



14918
(12048369)

Headlight Socket Assembly
For High-Low 9004 &
9007 Halogen Bulb
GM, Ford & Imports

UNIT PACKAGE: 1

HAVE YOU VISITED US ONLINE?

**Auveco's website has been completely renovated.
Our new design is user friendly with easy
navigation and ordering.**

**Product is searchable by car make, OEM number
and category, as well as, several attribute drop
downs within individual categories. All product
also has stock availability listed.**

**Make sure to head over to www.auveco.com
to receive up to date information
on all our products.**



19890

(Not Available from O.E.M.)

Back-Up Light Switch
Harness Connector
Fits Switches
C9TZ-15520C & SW-849
Ford Trucks & T-Bird 1967-On

UNIT PACKAGE: 1

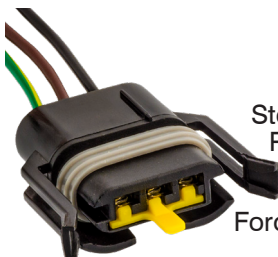

19125

(Not Supplied by O.E.M.)

Stop, Tail, Turn & Parking Lights
Plugs into Light Socket Base
For Double Filament
Wedge Type Bulbs
Ford Ranger, Explorer & Econoline
1991-On

UNIT PACKAGE: 1

Use with butt connectors on pages 205-211 • *Photos not actual size*



22184

(Ford: F1TZ-13411-A;
GM: 88860592)

Park, Stop & Turn Signal
Lights Socket Base
Bulb No. 3157
Three Terminals
Black Housing
90° Angle Base

Use with Auveco 19125
Ford Cars &
Trucks 1994 - On

UNIT PACKAGE: 1

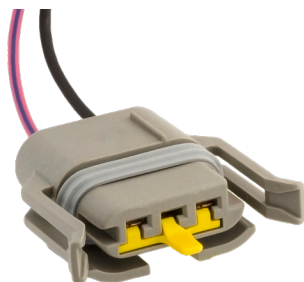

19126

(Not Supplied by O.E.M.)

Back-Up Lights Plugs into
Light Socket Base
For Single Filament
Wedge Type Bulbs
Ford Ranger, Explorer &
Econoline 1991-On

UNIT PACKAGE: 1

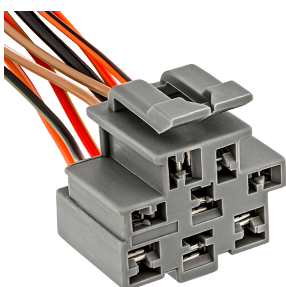

18463

(Not Supplied by O.E.M.)

Headlight Switch
Harness Connector
Fits Headlight Switches
E6DZ-11654A & F2DZ-11654A
Ford Taurus & Mercury Sable
with Rotary Knob 1994-86

UNIT PACKAGE: 1

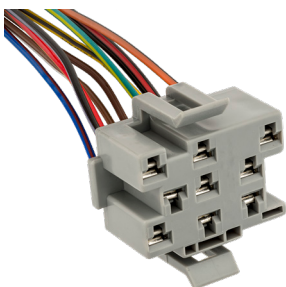

17624

(Not Supplied by O.E.M.)

Headlight Switch Assembly
Harness Connector
Fits Instrument Panel
Headlight Switch
E7TZ-11654-C
Ford Trucks: F150, F250, F350
& Bronco 1991-87

UNIT PACKAGE: 1

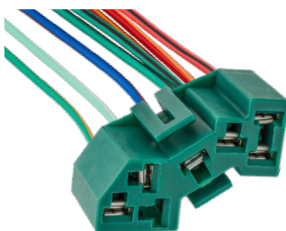

18464

(Not Supplied by O.E.M.)

Turn Signal Switch
Harness Connector
Fits Switch E7FZ-13341-A
Ford Tempo, Topaz, EXP, LN7,
Capri, Mustang, LTD, Marquis,
Escort & Lynx 1994-85

UNIT PACKAGE: 1

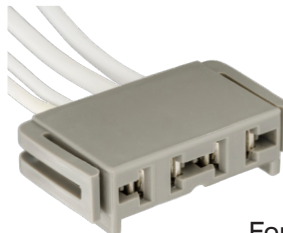

20547

(Not Supplied by O.E.M.)

Multi-Function Switch
Harness Connector
Fits 13K359 Switches E8DZ-B,
E8ZZ-B, E9DZ-A,B,C, E90Y-D,
E9SZ-B,D,E & F0ZZ-A,B
Ford Taurus, Sable, T-Bird, Cougar
and Continental 1993 - 86

UNIT PACKAGE: 1

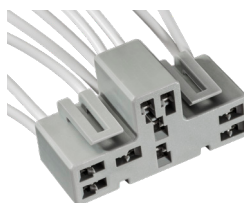

20548

(Not Supplied by O.E.M.)

Multi-Function Switch
Harness Connector
Fits 13K359 Switches E8DZ-B,
E8ZZ-B, E9DZ-A, B, C, E90Y-D,
E9SZ-B, D, E & F0ZZ-A, B
Ford Taurus, Sable, T-Bird, Cougar and
Continental 1993 - 86

UNIT PACKAGE: 1

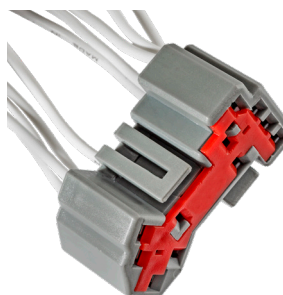

20246

(Not Supplied by O.E.M.)

Multi-Function Switch
Repair Harness
Eleven 18 Gauge Leads
Aerostar, E Van, Expedition,
Mustang, Navigator, Sable,
Taurus & Windstar 1992 - On

UNIT PACKAGE: 1

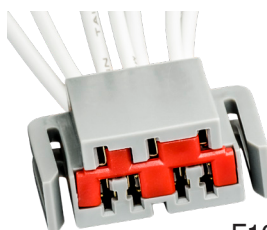

20550

(Not Supplied by O.E.M.)

Multi-Function Switch
Harness Connector
Fits 13K359 Switches
F1AZ-A, B, F1DZ-B, F1LY-B,
F10Y-D, F1VY-C, F3TZ-B, F3UZ-C,
F4ZZ-AA, F58Z-A, F5AZ-A, F5TZ-B, F65Z-AA, F6DZ-A,
F75Z-AB,AC,BA, F77Z-AA, F79Z-CA & F85Z-AA
Ford Aerostar, Bronco, Continental, Cougar,
Expedition, Explorer, F Pick-Ups, Mark Series,
Mountaineer, Mustang, Navigator, Ranger, Sable,
T-Bird, Taurus, Town Car & Windstar 1990 - On

UNIT PACKAGE: 1



18673

(Not Supplied by O.E.M.)

Multi-Function Switch
Harness Connector
(Turn Signal & Windshield Wiper)
Fits Switch E9DZ-13K359-A, B, C,
E8ZZ-13K359-B & F0ZZ-13K359-A
Ford Mustang 1993-87
Taurus & Sable 1989-86

UNIT PACKAGE: 1

Use with butt connectors on pages 205-211 • *Photos not actual size*

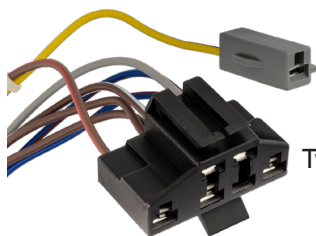

17623

(Not Supplied by O.E.M.)

EEC IV Test Plug
Repair Harness Connector
Two Connectors with eight 18
Gauge Leads
Ford 1983-On

UNIT PACKAGE: 1

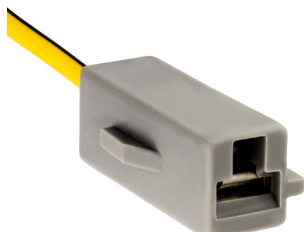

19581

(Not Supplied by O.E.M.)

EEC IV Test Plug
Repair Harness Connector
One 18 Gauge Wire Lead
**Component of Auveco
17623 Harness Connector**
Ford 1983-On

UNIT PACKAGE: 5



19881

(Not Supplied by O.E.M.)

Ignition Switch
Harness Connector
Used with Switches
D0TZ-11572A, SW944
Ford Trucks: 100-900 Series
1970-On

UNIT PACKAGE: 1



20853

(Not Supplied by O.E.M.)

Ignition Coil
Harness Connector
Two 16 Gauge Wire Leads
Fits Coils F7TZ-12029-CC &
1L2Z-12029-AA
Ford Cars & Lt. Duty Trucks
1999 - On

UNIT PACKAGE: 1



20172

(Not Supplied by O.E.M.)

EEC Relay Harness Connector
Used with Relay E3AZ-12A646-A
Two 18 Gauge Wire Leads,
Two 16 Gauge Wire Leads &
One 14 Gauge Wire lead
Ford Cars & Trucks 1981-On

UNIT PACKAGE: 1



20844

(Not Supplied by O.E.M.)

Electronic
Ignition Module
Harness Connector
Four 16 Gauge Wire Leads
Fits Modules
F2PZ-12A199-AA, DY683
Ford 1975 - On

UNIT PACKAGE: 1



20841

(Not Supplied by O.E.M.)

Electronic
Ignition Module
Harness Connector
Four 18 Gauge Wire Leads
Fits Module F2PZ-12A199-AA, DY683
Ford Cars & Lt. Trucks 1985 - 75
700 Series & Larger 1991 - 75

UNIT PACKAGE: 1

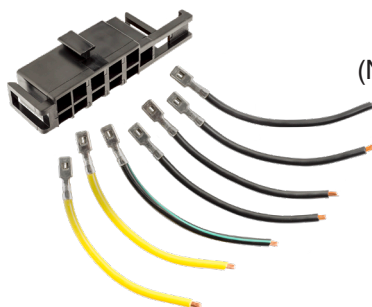

17684

(Not Supplied by O.E.M.)

Ignition Switch
Harness Connector
Fits Ignition Switch
E6FZ-11572A
Ford 1992-80

UNIT PACKAGE: 1

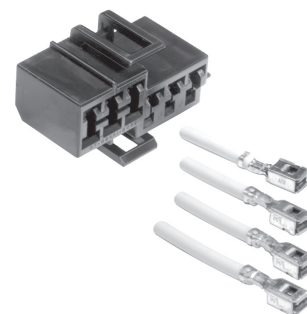

18676

(E6DZ-14A411-A)

Ignition Switch
Harness Connector
Fits Switch E7DZ-11572-A
Ford Taurus, Sable &
Lincoln Continental
1986-On

UNIT PACKAGE: 1



18214

(Not Supplied by O.E.M.)

Ignition Module
Harness Connector
Fits Ignition Module
E8TZ-12A297A
Ford Ranger: 1995-88

UNIT PACKAGE: 1

Use with butt connectors on pages 205-211 • *Photos not actual size*

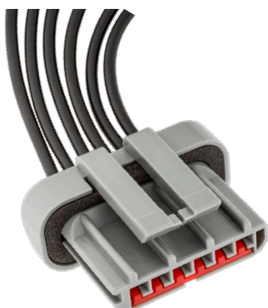

18217
(E5ZZ-12A209A)

Ignition Module &
Neutral Safety Switch
Harness Connector
For E.E.C. IV Ignition 1995-83
Ford Neutral Safety Switch
E80Z-7A247-A 1988-On

UNIT PACKAGE: 1



18819
(Not Supplied by O.E.M.)

Heater & Air Conditioner
Blower Switches
Harness Connector
Fits most Ford Switches with
Base Number 19986
1973-On

UNIT PACKAGE: 1

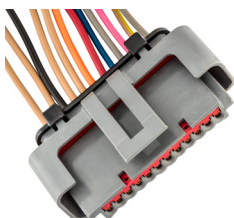

19623
(Not Supplied by O.E.M.)

Ignition Control Module Harness
For Modules F1AZ,
F4SZ-12072A & F5SZ-12072AA
Wire Gauge: 5 of 18 & 7 of 16
8" Leads
Ford: Full Size Trucks & Vans, T-Bird,
Cougar Lincoln Town & Mark 1991 - On

UNIT PACKAGE: 1

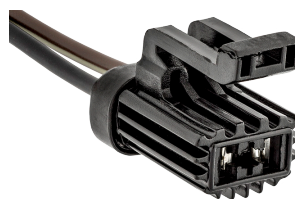

19582
(Not Supplied by O.E.M.)

Harness Connector for
Heater Blower Motor &
Radiator Cooling Fan Motor
Replaces Auveco 18213
Ford Truck & Vans 1986-82
Ford 4-Cylinder Engine
1979-On

UNIT PACKAGE: 5

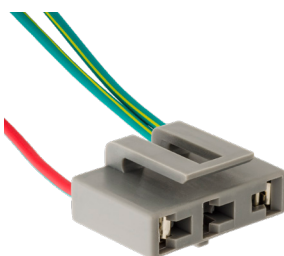

17661
(Not Supplied by O.E.M.)

Electronic Ignition Coil
Harness Connector
Fits Coil E73Z-12029A
Ford 1986-On

UNIT PACKAGE: 1



19883
(Not Supplied by O.E.M.)

Blower Motor Switch
Harness Connector
Used with Switch
E83Z-19986A, YH-481
Tempo & Topaz 1994-88

UNIT PACKAGE: 1

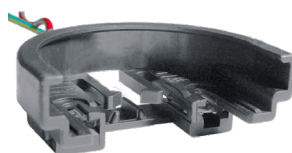

20839
(Not Supplied by O.E.M.)

Coil to Ignition
Harness Connector
Two 18 Gauge Wire Leads
Ford 1977 - On

UNIT PACKAGE: 10

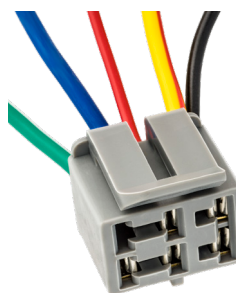

19887
(Not Supplied by O.E.M.)

Auxiliary Blower Switch
Harness Connector
Fits Switch F2UZ-19986C, YH-538
Ford Vans E150/350 1992-On

UNIT PACKAGE: 1

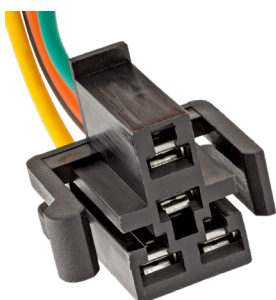

17620
(Not Supplied by O.E.M.)

Air Conditioning Blower
Motor Resistor Assembly
Harness Connector
Fits Resistor Assembly
E7TZ-19A706-A
Ford Trucks 1983 - On

UNIT PACKAGE: 1



20849
(Not Supplied by O.E.M.)

Blower Motor Switch
Harness Connector
Five 16 Gauge Wire Leads
Fits Switches D0HZ-19986-A, YH411
Ford Heavy Duty Trucks 1989 - 1968

UNIT PACKAGE: 1

Use with butt connectors on pages 205-211 • *Photos not actual size*



17598

(Not Supplied by O.E.M.)
Air Conditioning Clutch
Cycling Pressure Switch
Harness Connector
Fits Switch E35Y-19E561-A
Ford 1980-On

UNIT PACKAGE: 1

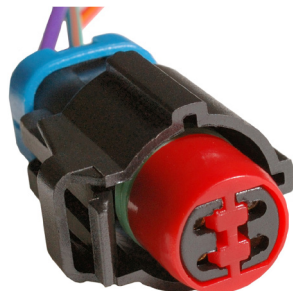

20843

(F81Z-19D887-AA, WPT-169,
1U2Z-14S411-AEA)
A/C Clutch Cycling
Pressure Switch
Harness Connector
Four 16 Gauge Wire Leads
Fits Switches F5VY-19E561-A,
F3AZ-19D594-C,
F5TZ-19D594-AA & YH-592
Ford 1990 - On

UNIT PACKAGE: 1

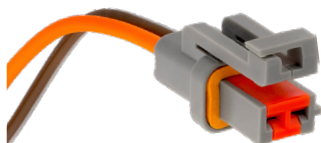

17617

(Not Supplied by O.E.M.)
Gray
Engine Cooling Fan
Motor Switch
Harness Connector
Fits Switch E43Z-8B607-A
Ford 1984-On

UNIT PACKAGE: 1



17618

(Not Supplied by O.E.M.)
Black
Engine Cooling Fan
Motor Switch
Harness Connector
Fits Switches E5SZ-8B607-A &
E4FZ-8B607-A
Ford 1984-On

UNIT PACKAGE: 1



19661

(Not Supplied by O.E.M.)
Blower Motor Resistor
Harness Connector
Fits Resistors F1CZ-19A706-A
& F7CZ-19A706-AA
One Connector has one each of
8" Long 20 Gauge, 16 Gauge, 14
Gauge & 12 Gauge GXL Wire Leads.
The other Connector has one 8" Long
12 Gauge GXL Wire Lead.
Ford Escort & Tracer 1991-On

UNIT PACKAGE: 1



22185

(Ford: 1U2Z-14S411-BHA,
WPT-153)
Blower Motor Resistor
Harness Connector
Two 10 Gauge &
Three 20 Gauge
TXL Wire Leads
Ford, Lincoln &
Mercury 2011 - 1991

UNIT PACKAGE: 1

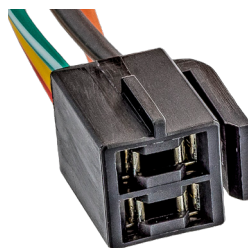

20277

(Not Supplied by O.E.M.)
Heater/Air Conditioner
Fan Speed Switch
Harness Connector
Two 12 Gauge, one 14 Gauge &
One 16 Gauge Leads
Fits Switches E6DZ-A, E9SZ-A,
F2DZ-A & F2UZ-19986A,B
Ford Cougar, E Van, Mustang, Sable,
Taurus & T-Bird 1986 - On

UNIT PACKAGE: 1

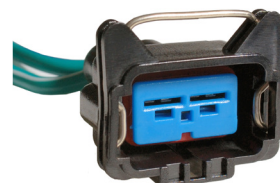

20852

(Not Supplied by O.E.M.)
Radiator Cooling
Motor & Resistor
Harness Connector
Two 12 Gauge Leads
For Resistor F5RZ-8L603-AC &
Motors F8RZ-8C607-GC, GE, RF28, RF76 & RF81
Ford Contour, Mystique & Cougar 1995 - On

UNIT PACKAGE: 1

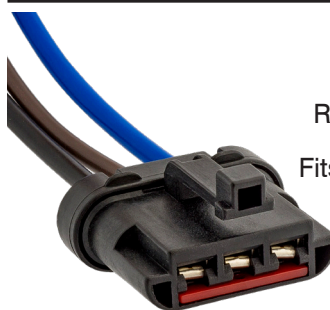

20549

(Not Supplied by O.E.M.)
Radiator Cooling Fan Motor
Harness Connector
Fits Fan & Shroud Assemblies
F4DZ-8C607B &
F5CA-8C607A
Ford Contour, Continental,
Escort, Mystique,
Sable & Taurus 1997 - 90

UNIT PACKAGE: 1

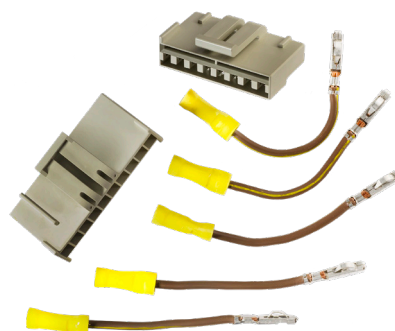

17619

(E4FZ-8C290-A)

Engine Cooling Fan
Harness Connector
Wiring Kit
Ford 4 Cylinder
(2.3 Engine)
with Air Conditioning
1983-On

UNIT PACKAGE: 1